

DA-683 Series Hardware Manual

Second Edition, August 2012

www.moxa.com/product



© 2012 Moxa Inc. All rights reserved.
Reproduction without permission is prohibited.

DA-683 Series Hardware Manual

The software described in this manual is furnished under a license agreement and may be used only in accordance with the terms of that agreement.

Copyright Notice

Copyright ©2012 Moxa Inc.
All rights reserved.
Reproduction without permission is prohibited.

Trademarks

The MOXA logo is a registered trademark of Moxa Inc.
All other trademarks or registered marks in this manual belong to their respective manufacturers.

Disclaimer

Information in this document is subject to change without notice and does not represent a commitment on the part of Moxa.

Moxa provides this document as is, without warranty of any kind, either expressed or implied, including, but not limited to, its particular purpose. Moxa reserves the right to make improvements and/or changes to this manual, or to the products and/or the programs described in this manual, at any time.

Information provided in this manual is intended to be accurate and reliable. However, Moxa assumes no responsibility for its use, or for any infringements on the rights of third parties that may result from its use.

This product might include unintentional technical or typographical errors. Changes are periodically made to the information herein to correct such errors, and these changes are incorporated into new editions of the publication.

Technical Support Contact Information

www.moxa.com/support

Moxa Americas

Toll-free: 1-888-669-2872
Tel: +1-714-528-6777
Fax: +1-714-528-6778

Moxa Europe

Tel: +49-89-3 70 03 99-0
Fax: +49-89-3 70 03 99-99

Moxa China (Shanghai office)

Toll-free: 800-820-5036
Tel: +86-21-5258-9955
Fax: +86-21-5258-5505

Moxa Asia-Pacific

Tel: +886-2-8919-1230
Fax: +886-2-8919-1231

Table of Contents

1. Introduction	1-1
Overview	1-2
Model Descriptions and Package Checklist.....	1-2
Appearance.....	1-3
Features	1-4
Hardware Block Diagram	1-4
Hardware Specifications	1-5
Non-standard Baudrates	1-6
2. Hardware Installation	2-1
Placement Options	2-2
Desktop	2-2
Rack mounting.....	2-2
Wiring Requirements.....	2-4
Connecting the Power	2-5
Wiring the Power Inputs	2-5
Power Input Wiring Description	2-6
HIPOT (Dielectric Strength) Testing	2-8
Reset Button	2-8
Front Panel LED.....	2-8
Connecting to a Display	2-9
Connecting a PS/2 Keyboard and Mouse	2-10
Connecting USB Devices	2-11
LAN Ports	2-11
Connecting Digital Input/Output Channels	2-12
Upgrading the Memory Module	2-12
Installing a CompactFlash Card	2-14
Installing a SATA Hard Disk	2-15
Installing a PCI 104 Board	2-17
Upgrading a DOM	2-18
Inserting and Removing Expansion Modules.....	2-18
3. BIOS Setup	3-1
Entering the BIOS Setup Utility	3-2
Main Information	3-2
Modifying the BIOS Main Settings	3-3
Advanced Settings.....	3-3
Security Settings.....	3-9
Power Settings.....	3-10
Boot Settings.....	3-11
Exit Settings.....	3-12
Upgrading the BIOS	3-13
A. Safety Installation Instructions	A-1
B. Regulatory Statement Approval	B-1

1

Introduction

Thank you for purchasing the Moxa DA-683 series x86-based industrial ready-to-run embedded computer.

This manual introduces the hardware installation, connector interfaces and BIOS setup of the DA-683. For software configuration and management, please refer to the user's manual for your operating system.

The following topics are covered in this chapter:

- **Overview**
- **Model Descriptions and Package Checklist**
- **Appearance**
- **Features**
- **Hardware Block Diagram**
- **Hardware Specifications**
- **Non-standard Baudrates**

Overview

The DA-683 computers are based on the Intel x86 processor and support DVI-I, 6 Gigabit Ethernet ports, 2 RS-232 serial ports, CompactFlash, and USB. The DA-683 comes in a standard 19-inch, 2U high form factor.

With a dual-core processor, the DA-683 computer is powerful enough for many industrial tasks yet consumes little power, to create a cost-effective solution for industrial applications. In addition, compliance with IEEE 1588 (Linux models only) delivers verified precision time protocol and clock synchronization functionality to deliver a highly accurate timestamps for event loggers in the power substation system.

Moreover, the DA-683 computers are IEC-61850-3 certified, guaranteeing system stability and reliability when used in the power industry. As an added-value, the DA-683 features a modular design with two independent slots for tremendous integration and expansion flexibility. Users can add a variety of communication modules, including an 8-port RS-232/422/485 module, an 8-port RS-422/485 module, a 4-port 10/100 Mbps LAN module, 8-port 10/100 Mbps switch module, and a universal PCI expansion module.

Wide temperature models of the DA-683 Series that operate reliably in a -40 to 70°C operating temperature range are also available, offering an optimal solution for applications subjected to harsh environments.

The DA-683 computers run Linux, or Windows XP Embedded (pre-installed), providing a friendly environment for developing sophisticated application software. Moxa provides thorough product support to make the programmer's job easier, and helps programmers develop bug-free code quickly and at a lower cost.

These features make the DA-683 computers excel in a wide array of power automation applications.

Model Descriptions and Package Checklist

The DA-683 Series includes the following models:

- **DA-683-SP-XPE:** x86 ready-to-run rackmount computer with 1.66 GHz CPU, DVI-I, 6 Giga LANs, 2 RS-232 serial ports, 4 DIs + 4 DOs, 2 peripherals expansion slots, CompactFlash, 4 USB, single power, Windows Embedded Standard 2009, -10 to 60°C operating temperature
- **DA-683-SP-LX:** x86 ready-to-run rackmount computer with 1.66 GHz CPU, DVI-I, 6 Giga LANs, 2 RS-232 serial ports, 4 DIs + 4 DOs, 2 peripherals expansion slots, CompactFlash, 4 USB, single power, Linux, -10 to 60°C operating temperature
- **DA-683-DPP-T-XPE:** IEC 61850-3 x86 ready-to-run rackmount computer with 1.66 GHz CPU, DVI-I, 6 Giga LANs, 2 RS-232 serial ports, 4 DIs + 4 DOs, 2 peripherals expansion slots, CompactFlash, 4 USB, dual power, Windows Embedded Standard 2009, -40 to 70°C operating temperature
- **DA-683-DPP-T-LX:** IEC 61850-3 x86 ready-to-run rackmount computer with 1.66 GHz CPU, VGA, 6 Giga LANs, 2 RS-232 serial ports, 4 DIs + 4 DOs, 2 peripherals expansion slots, CompactFlash, 4 USB, dual power, Linux, -40 to 70°C operating temperature

Each model is shipped with following standard items:

- 1 DA-683 Embedded Computer
- Quick Installation Guide
- Documentation & Software CD
- Ethernet Cable: RJ45 to RJ45 cross-over cable, 100 cm
- Product Warranty Statement

Appearance

Front View

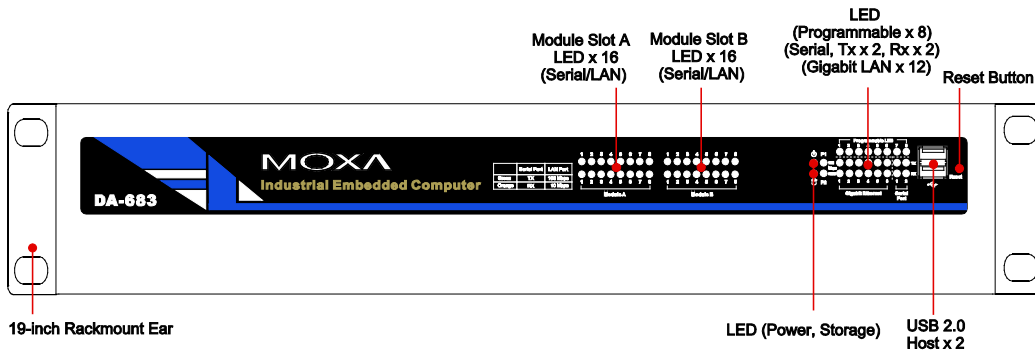

Rear View

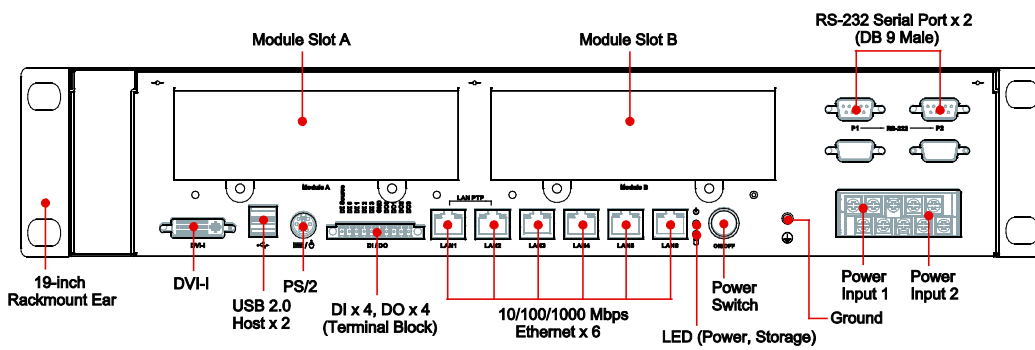

Dimensions

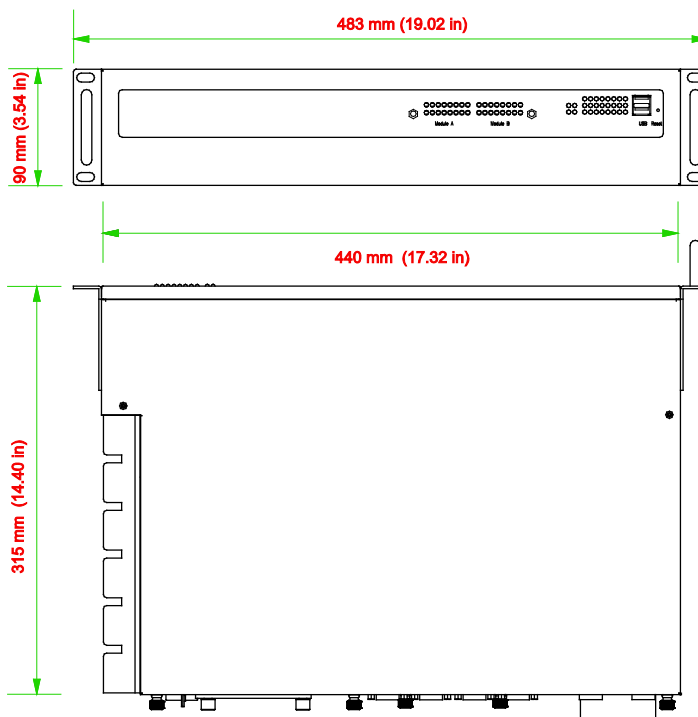

Features

The DA-683 computer has the following features:

- IEC 61850-3 certified for power substation automation systems (DPP-T models only)
- Intel Dual Core Atom D510 1.66 GHz processor
- DDR2 SODIMM socket, supporting DDR2 667 up to 2 GB (max.)
- 6 10/100/1000 Mbps Ethernet ports
- 2 RS-232 serial ports
- 4 USB 2.0 ports for high speed peripherals
- 4 DIs, 4 DOs
- CompactFlash socket for storage expansion
- 2 SATA-300 connectors for hard disk drive expansion
- 2 PCI expansion slots for inserting expansion modules
- Dual power input models available
- Ready-to-run Embedded Linux, or Windows Embedded Standard 2009 platform
- -40 to 70°C wide temperature models available



ATTENTION

Refer to the "Non-standard Baudrates" section for instructions on how to calculate which baudrates are supported.

Hardware Block Diagram

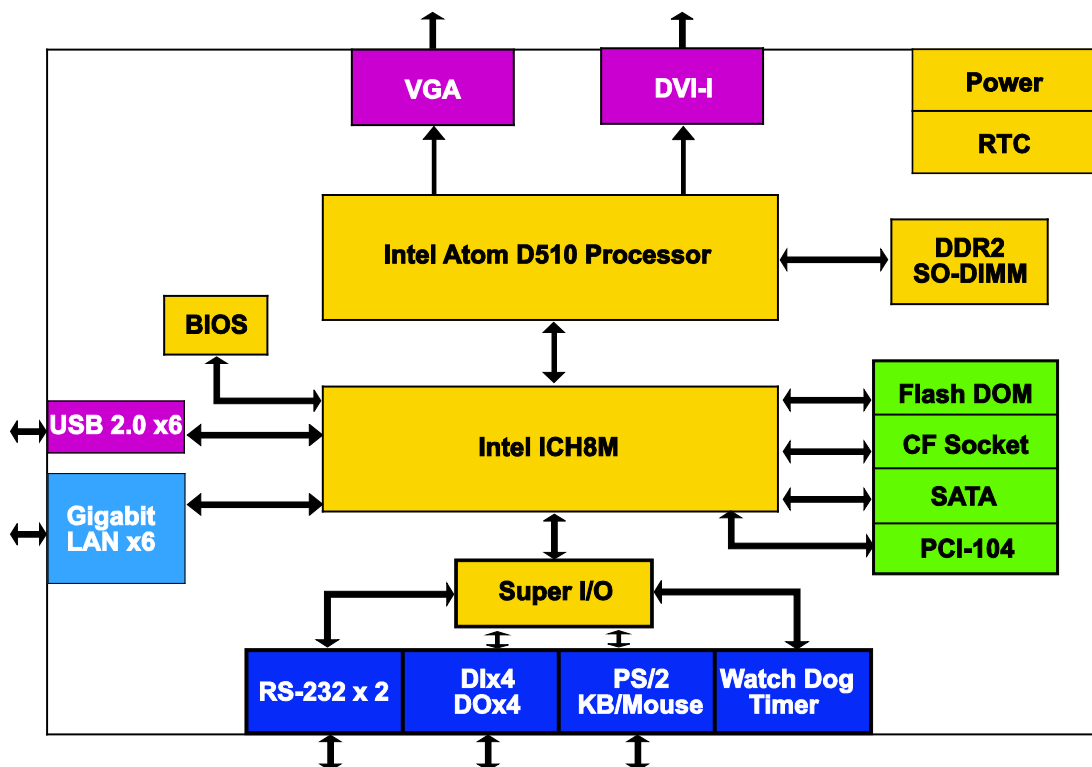

Hardware Specifications

Computer

CPU: Intel Dual Core Atom D510 1.66 GHz processor

OS (pre-installed): Linux or Windows Embedded Standard 2009

System Chipset: Intel Pineview-D + ICH8M

BIOS: 16 Mbit Flash BIOS, PCI Plug & Play, ACPI function support

FSB: 667 MHz

System Memory: 1 x 200-pin DDR2 SODIMM socket supporting DDR2 667; up to 2 GB, with 1 GB built in

Expansion Bus: PCI/104 interface reserved

USB: USB 2.0 compliant hosts, Type A connector x 4, supports system boot up

Storage

Built-in: 2 GB industrial DOM onboard to store OS

Storage Expansion: CompactFlash socket for CF card expansion, supporting CF Type-I/II

HDD Support: 2 SATA-300 connectors for HDD expansion

Other Peripherals

KB/MS: 1 PS/2 interface, supports standard PS/2 keyboard and mouse through Y-type cable

Display

Graphics Controller: Intel® GMA3150 graphics controller in Intel D510 card

DVI Interface:

- Analog RGB display; output resolution up to 2048 x 1536 @ 60 Hz
- Digital DVI display; output resolution up to 1024 x 768 @ 60 Hz

Ethernet Interface

LAN: 6 auto-sensing 10/100/1000 Mbps Gigabit ports

Magnetic Isolation Protection: 1.5 KV built-in

Serial Interface

Serial Standard: 2 RS-232 ports (DB9 male)

Serial Signals

RS-232: TxD, RxD, DTR, DSR, RTS, CTS, DCD, GND, RI

Digital Input

Input Channels: 4, source type

Input Voltage: 0 to 30 VDC

Digital Input Levels for Dry Contacts:

- Logic level 0: Close to GND
- Logic level 1: Open

Digital Input Levels for Wet Contacts:

- Logic level 0: +3 V max.
- Logic level 1: +10 V to +30 V (source to DI)

Connector Type: 10-pin screw terminal block (4 DI points, 4 DO points, DI source, GND)

Isolation: 3 KV optical isolation

Digital Output

Output Channels: 4, sink type

Output Current: Max. 200 mA per channel

On-state Voltage: 24 VDC nominal, open collector to 30 V

Connector Type: 10-pin screw terminal block (4 DI points, 4 DO points, DI source, GND)

Isolation: 3 KV optical isolation

LEDs

System: Power, Storage, Power Failure x 2

Gigabit LAN: 100M x 6, 1000M x 6

Serial: TX/RX

Communication: Module A x 16, Module B x 16

Programmable: LED x 8

Switches and Buttons

Power Switch: on/off (on rear panel)

Reset Button: To reset system hardware (on front panel)

Physical Characteristics

Housing: SECC sheet metal (1 mm)

Weight: 4 kg

Dimensions: 315 x 440 x 90 mm (12.40 x 17.32 x 3.54 in) (without rackmount ears)

Mounting: Standard 19-inch rackmount

Environmental Limits

Operating Temperature:

Standard models: -10 to 60°C (14 to 140°F)

DPP-T models: -40 to 70°C (-40 to 158°F)

Storage Temperature:

Standard models: -20 to 80°C (-4 to 176°F)

DPP-T models: -40 to 85°C (-40 to 185°F)

Ambient Relative Humidity: 5 to 95% (non-condensing)

Anti-vibration: 7 mm (2-9 Hz), 20 m/s/s (9-200 Hz), 15 m/s/s (200-500 Hz) @ IEC-61850-3, IEC 60870-2-2/Cm/(3M6)/(4M6), sine wave, 2-500 Hz, 1 Oct/min, 10 cycles, 2 hrs 40 mins per axis

Anti-shock: 300 m/s² @ IEC-61850-3, IEC 60870-2-2/Cm/(3M6)/(4M6), half sine wave, 11 ms

Power Requirements

Input Voltage: 100 to 240 VAC, 50/60 Hz, 0.9-0.4 A

Power Consumption: 40 W

Standards and Certifications

Safety: UL/cUL (UL60950-1, CSA C22.2 No. 60950-1-03), LVD (EN60950-1), CCC (GB4943)

EMC: CE (EN55022, EN61000-3-2, EN61000-3-3, EN55024), FCC (Part 15 Subpart B, CISPR 22 Class), CCC (GB9254, GB 17625.1)

Green Product: RoHS, CRoHS, WEEE

Power Automation: IEC 61850-3 (DPP-T models only)

Reliability

Alert Tools: Built-in buzzer and RTC (real-time clock) with lithium backup battery

Automatic Reboot Trigger: Built-in WDT (watchdog timer) supporting 1-255 level time interval system reset, software programmable

MTBF (mean time between failures): 134,407 hrs

Warranty

Warranty Period: 3 years

Details: See www.moxa.com/warranty

Non-standard Baudrates

Moxa's UART ASIC, supports most non-standard baudrates in the range 50 bps to 921.6 Kbps. In fact, supported baudrates are much denser towards the lower values. For example, no baudrates are supported between the integers 5320 and 5323, but 49 baudrates are supported between the integers 387 and 388. Of course this is the way it should be, since serial devices that require using non-standard baudrates generally use slower baudrates.

Before using a serial device that requires using a non-standard baudrate, you must first check that the DA-683 supports a baudrate within the tolerance specified by the serial device manufacturer.

Use the following formula to calculate which baudrates are supported by the DA-683:

(A) Baudrate = $921600 / (N + M/8)$ bps, for $N = 1, 2, \dots, 18431$, $M = 0, 1, 2, \dots, 7$

or

(B) Baudrate = $8 \times 921600 / K$ bps, for $K = 8, 9, \dots, 147456$

If you are a programmer and you need to write a driver for your serial device, then you may need to use formula A. If you have a serial device that requires using a non-standard baudrate, then you can use formula B to determine if the DA-683 supports a baudrate within the tolerance specified by the serial device manufacturer.

Example: Your serial device requires using a baudrate of 5340 bps and has a tolerance of 2 bps. Can the DA-683 be used with this device?

Solution: Set formula B to the desired baudrate and then solve for K.

$$8 \times 912600/K = 5338 \implies K = 1367.703259\dots$$

This shows that the supported baudrate closest to 5340 comes from setting $K=1367$ or $K=1368$.

$$K=1368 \implies \text{Baudrate1} = 5336.842105\dots$$

$$K=1367 \implies \text{Baudrate2} = 5340.746159\dots$$

Since $5338 - \text{Baudrate1} < 2$, we can see that the DA-683 supports the serial device.

Note that we can use formula A to generate the so-called "standard" baudrates, which come from setting $M=0$, and setting N equal to certain integers.

Standard Baudrates					
Baudrate	N	M	Baudrate	N	M
115200	8	0	1800	512	0
57600	16	0	1200	768	0
38400	24	0	600	1536	0
19200	48	0	300	3072	0
9600	96	0	150	6144	0
7200	128	0	75	12288	0
4800	192	0	50	18432	0
2400	384	0			



WARNING

Communication between a serial device and a Moxa UART port may not work correctly if the serial device uses a baudrate that it not within the correct tolerance of a baudrate calculated from either formula A or formula B.

Hardware Installation

The DA-683 Series of embedded computers are compact and rugged, making them suitable for industrial applications. The LED indicators allow users to monitor performance and identify trouble spots quickly, and multiple ports are provided for connecting a variety of different devices. The DA-683 embedded computers come with a reliable and stable hardware platform that lets you devote the bulk of your time to application development. This chapter describes hardware installation and connector interfaces of the DA-683 embedded computers.

The following topics are covered in this chapter:

- ❑ **Placement Options**
 - Desktop
 - Rack mounting
- ❑ **Wiring Requirements**
- ❑ **Connecting the Power**
- ❑ **Wiring the Power Inputs**
- ❑ **Power Input Wiring Description**
- ❑ **HIPOT (Dielectric Strength) Testing**
- ❑ **Reset Button**
- ❑ **Front Panel LED**
- ❑ **Connecting to a Display**
- ❑ **Connecting a PS/2 Keyboard and Mouse**
- ❑ **Connecting USB Devices**
- ❑ **LAN Ports**
- ❑ **Connecting Digital Input/Output Channels**
- ❑ **Upgrading the Memory Module**
- ❑ **Installing a CompactFlash Card**
- ❑ **Installing a SATA Hard Disk**
- ❑ **Installing a PCI 104 Board**
- ❑ **Upgrading a DOM**
- ❑ **Inserting and Removing Expansion Modules**

Placement Options

Desktop

Place your DA-683 on a clean, flat, well-ventilated desktop. For better ventilation, leave some space between the DA-683 and other equipment. Do not place equipment or objects on top of the DA-683, as this might damage the computer's internal components.

Rack mounting

The DA-683 has rackmount supports for installing the embedded computer on a standard rack.



ATTENTIONS

For maximum safety, at least two persons should work together to lift, place, and attach the embedded computer to the rack.

Before you lift or move the embedded computer, make sure that the embedded computer is turned off and the power to the rack system is turned off.

Four rackmount screws are required to attach the DA-683 to a standard rack.

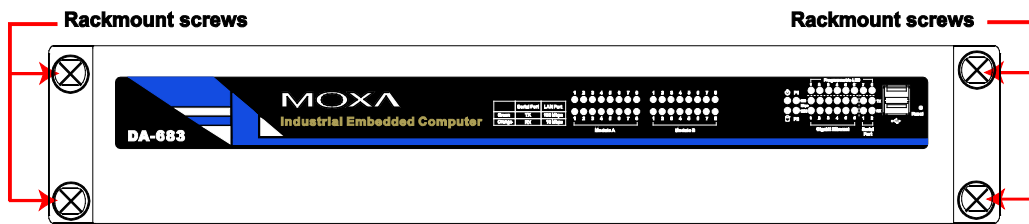

Follow these steps to install the DA-683 on a rack.

Step 1: Installing the rackmount supports.

Take the rackmount supports out of the packages. There are two packages, each of which contains 1 rackmount support, 1 rackmount hanger, 2 FMSM5X10 screws, and 6 FMSM4X6 screws.

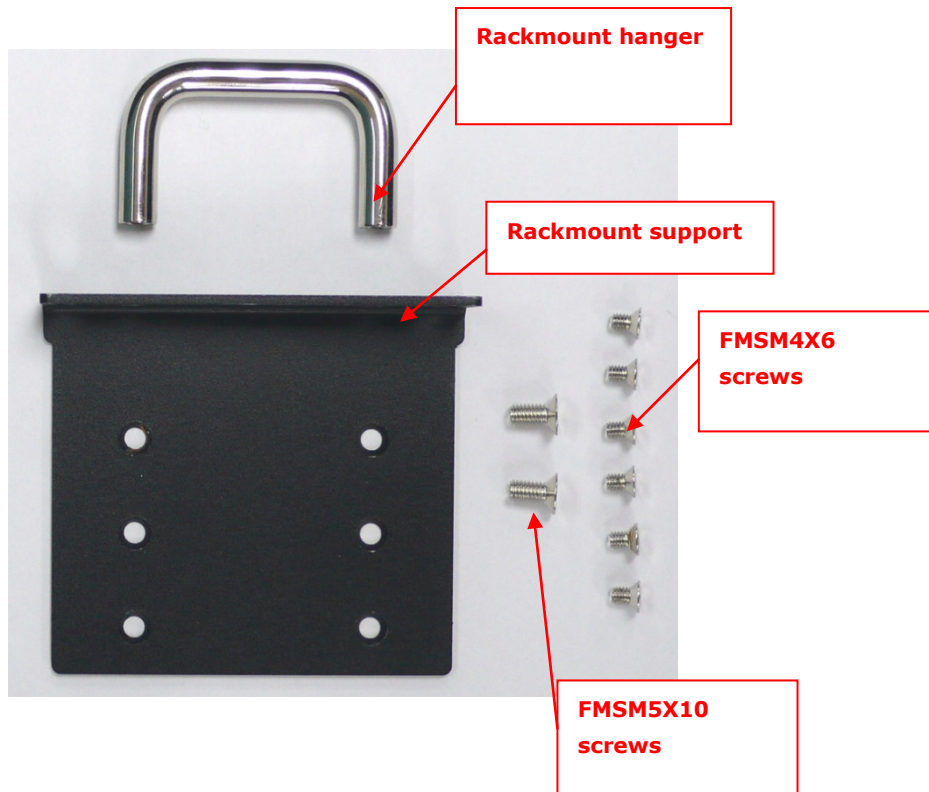

Step 2: Installing rackmount hanger to the support.

Use 2 FMSM5X10 screws to attach the rackmount hanger to the ear. Repeat this procedure for the additional support and hanger.

**Step 3: Installing the rackmount ears to the DA-683.**

Use 6 screws to attach one rackmount ear to one side of the DA-683. Repeat this procedure for the ear on the other side of the DA-683.

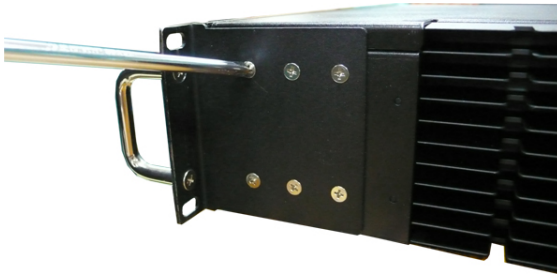
**Step 4: Installing the DA-683 to a rack.**

Gently slide the DA-683 onto the rack, and then use screws provided by the rack supplier to fix the rackmount support to the rail.



NOTE That four screws are required to attach the DA-683 to the rack. Use two screws on the left side and two screws on the right side.

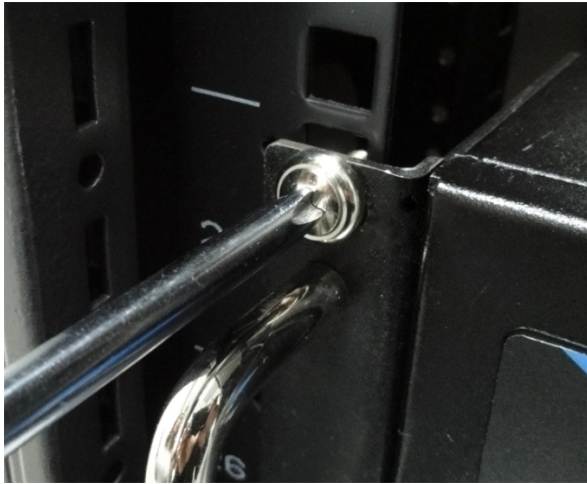

As a final check, make sure that the four screws are firmly attached to the rack.

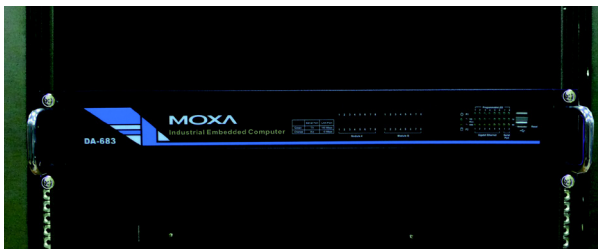

Wiring Requirements

The following common safety precautions should be observed before installing any electronic device:

- Use separate paths to route wiring for power and devices. If power wiring and device wiring paths must cross, make sure the wires are perpendicular at the intersection point.
- You can use the type of signal transmitted through a wire to determine which wires should be kept separate. The rule of thumb is that wiring that shares similar electrical characteristics can be bundled together.
- Keep input wiring and output wiring separate.
- When necessary, it is strongly advised that you label wiring to all devices in the system.



ATTENTION

Do not run signal or communication wiring and power wiring in the same wire conduit. To avoid interference, wires with different signal characteristics should be routed separately.



ATTENTION

Safety First!

Be sure to disconnect the power cord before installing and/or wiring your device.

Electrical Current Caution!

Calculate the maximum possible current in each power wire and common wire. Observe all electrical codes dictating the maximum current allowable for each wire size.

If the current goes above the maximum ratings, the wiring could overheat, causing serious damage to your equipment.

Temperature Caution!

Be careful when handling the unit. When the unit is plugged in, the internal components generate heat, and consequently the outer casing may feel hot to the touch.

Connecting the Power

The DA-683 offers both single power and dual power inputs. Use a screwdriver to remove the screws. Connect the power cord to the screws and then attach the screws to the unit. For single models (SP), use Power 1 only; for dual power models (DPP-T), use both Power 1 and Power 2 for power input installation. Refer to the following figure for detailed information.

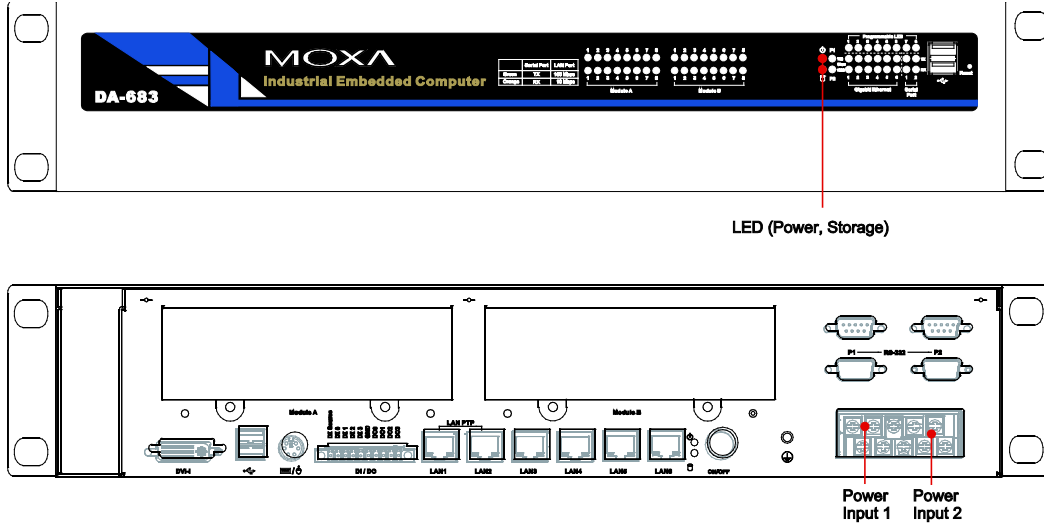

Wiring the Power Inputs

For SP Models

PWR 1

+/L	NC	NC	NC	NC
-/N	⏏	NC	NC	NC

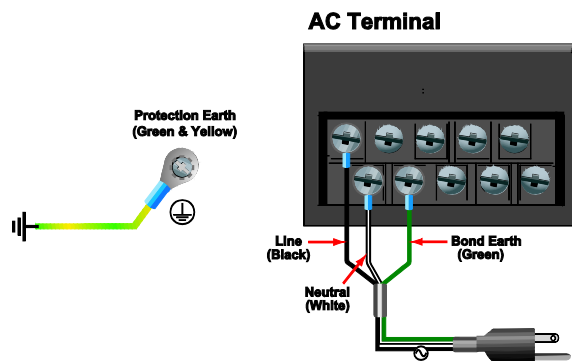
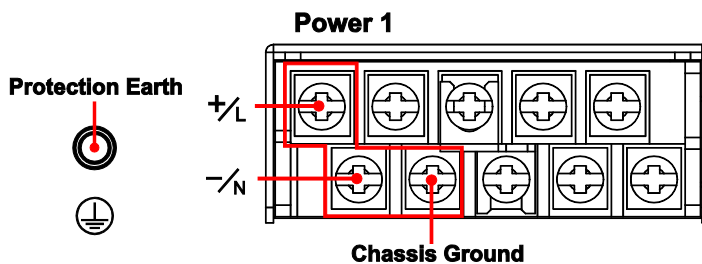

For DPP-T Models

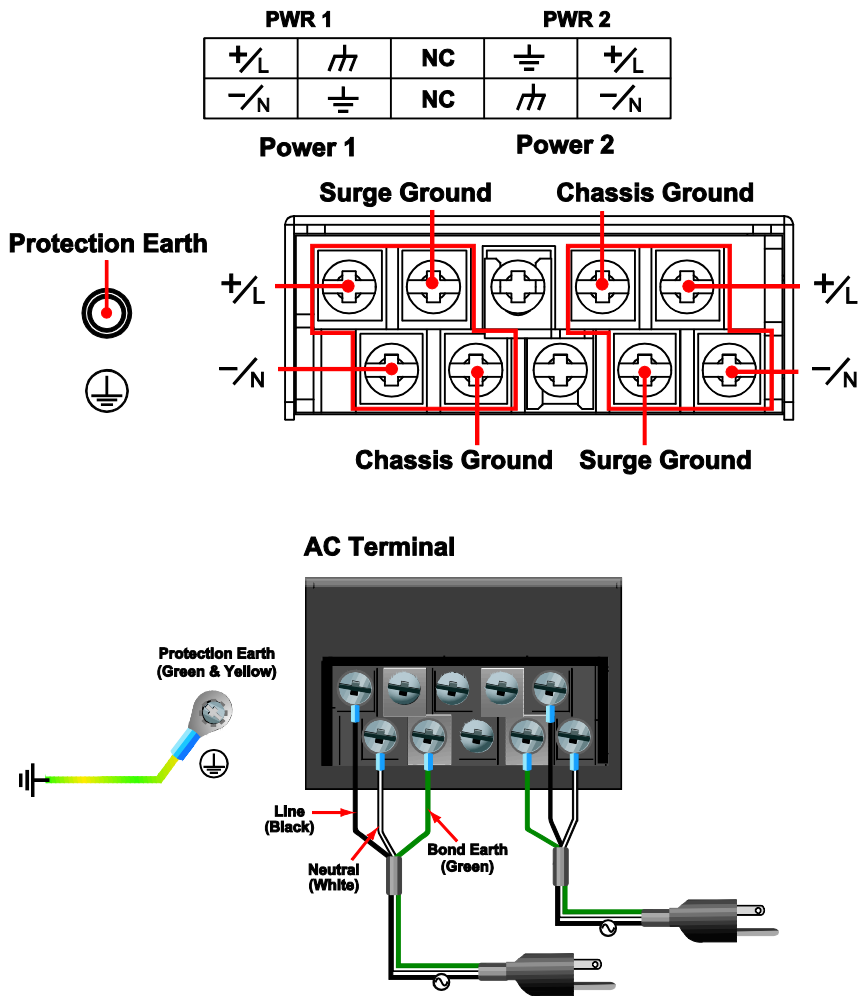

Power Input Wiring Description

Read the following section for a detailed power input wiring description.

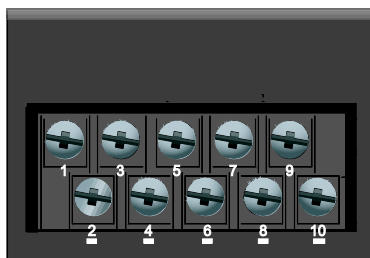

1	2	3	4	5	6	7	8	9	10
PWR1		/ /		NC	≡		PWR2		/ /
L	N				L	N			

Terminal Number	Description	Note
1	PWR1 Line	PWR1 Line + is connected, or to the Line terminal for the AC power source.
2	PWR1 Neutral	PWR1 Neutral – is connected to the Neutral terminal for the AC power source.
3	PWR1 Surge Ground	PWR1 Surge Ground is connected to the Chassis Ground via a jumper on the terminal block. Surge Ground is used as the ground conductor for all surge and transient suppression circuitry. <i>NOTE: Surge Ground must be disconnected from Chassis Ground during HIPOT (dielectric strength) testing.</i>
4	Chassis Ground	Chassis Ground is connected to the Safety Ground terminal for AC inputs, chassis ground connects to both power supply surge grounds via a removable jumper.
5	NC	No function
6	NC	No function
7	Chassis Ground	Chassis Ground is connected to the Safety Ground terminal for AC inputs chassis ground connects to both power supply surge grounds via a removable jumper.
8	PWR2 Surge Ground	PWR2 Surge Ground is connected to the Chassis Ground via a jumper on the terminal block. Surge Ground is used as the ground conductor for all surge and transient suppression circuitry. NOTE: Surge Ground must be disconnected from Chassis Ground during HIPOT (dielectric strength) testing.
9	PWR2 Line	PWR2 Line to the Line terminal for the AC power source.
10	PWR2 Neutral	PWR2 Neutral is connected to the Neutral terminal for the AC power source.

For AC Power Input

1. PWR1 Line should be connected to AC (Line).
2. PWR1 Neutral should be connected to AC (Neutral).
3. Surge Ground is connected to the Chassis Ground via a braided cable or other appropriate grounding wire. Surge Ground is used as the ground conductor for all surge and transient suppression circuitry internal to the protection board.
4. Chassis Ground should be connected to the AC Ground terminal.



ATTENTION

1. Equipment must be installed according to the applicable country wiring codes.
2. Surge Ground **MUST** be disconnected from the Chassis Ground during HIPOT (dielectric strength) testing.
3. All line-to-ground transient energy is shunted to the Surge Ground terminal. In cases where users require the inputs to be isolated from the ground, remove the ground braid between Surge and Chassis Ground. Note that all line-to-ground transient protection circuitry will be disabled.

HIPOT (Dielectric Strength) Testing

Before performing the HIPOT test, you MUST have the jumpers removed and the braided ground cable disconnected. This is required to prevent the transient/surge suppression circuitry, which is connected to Surge Ground from being activated during the HIPOT test.

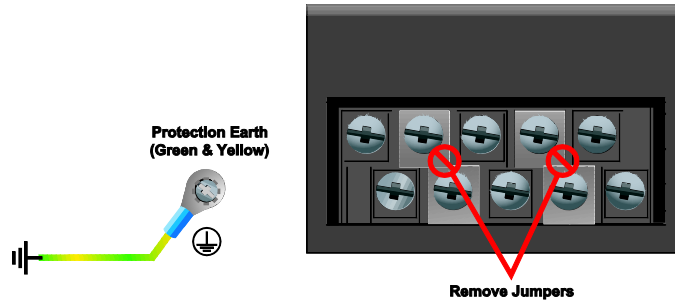

When finished, press the Power Switch button to start the system. It will take about 30 to 60 seconds for your operating system to boot up.

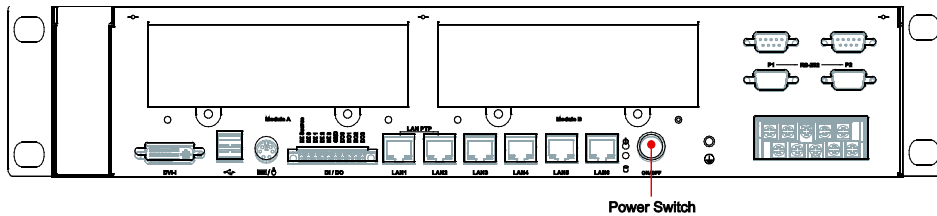

Reset Button

Pressing the Reset button initiates a hardware warm reboot. The button plays the same role as a desktop PC’s reset button. After pressing the reset button, the system will reboot automatically. During normal use, you should NOT use the Reset Button. You should only use this button if the software is not working properly. To protect the integrity of data being transmitted or processed, you should always reset the system from the operating system with the software reboot function.

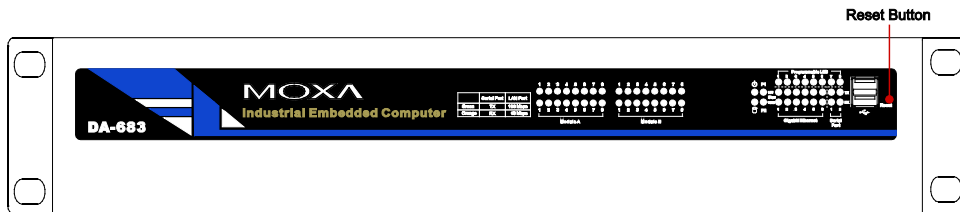

Front Panel LED

There are 60 LED indicators on the front panel. Information about each LED is given in the following table. The additional ports LEDs, named Port 1 and Port 2 are temporarily reserved for future use.

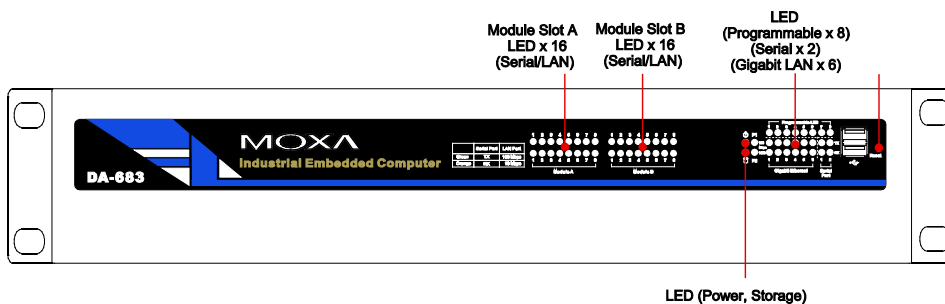

LED Name	Color	LED Description
Power	Green	Power is on
	Off	No power input or power error
Storage	Yellow / Blinking	Data is being written to or to read from the storage unit
	Off	Storage unit is idle
Ethernet Port 1000 Mbps	Green	1000 Mbps of Ethernet port is active
	Off	No activity
Ethernet Port 100 Mbps	Yellow	100 Mbps of Ethernet port is active
	Off	10 Mbps or no activity
Serial Port TX 1-2	Green	Serial port is transmitting data
	Off	No operation
Serial Port RX 1-2	Yellow	Serial port is receiving data
	Off	No operation
Module Slot A	Green	Serial port is transmitting data, or 100 Mbps Ethernet port is active
	Orange	Serial port is receiving data, or 10 Mbps Ethernet port is active
Module Slot B	Green	Serial port is transmitting data, or 100 Mbps Ethernet port is active
	Orange	Serial port is receiving data, or 10 Mbps Ethernet port is active

Connecting to a Display

Your DA-683 embedded computer comes with 25-pin DVI-I female connector to connect to the DVI-I monitor. Be sure to remove the power before you connect or disconnect the monitor cable.

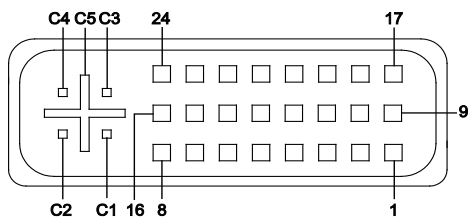

Pin No.	Signal Definition	Pin No.	Signal Definition
1	T.M.D.S. Data2-	16	Hot Plug Detect
2	T.M.D.S. Data2+	17	T.M.D.S. Data0-
3	T.M.D.S. Data2/4 Shield	18	T.M.D.S. Data0+
4	N/C	19	T.M.D.S. Data0/5 Shield
5	N/C	20	N/C
6	DDC Clock	21	N/C
7	DDC Data	22	T.M.D.S. Clock Shield
8	Analog Vertical Sync	23	T.M.D.S. Clock+
9	T.M.D.S. Data1-	24	T.M.D.S. Clock-
10	T.M.D.S. Data1+	C1	Analog Red
11	T.M.D.S. Data1/3 Shield	C2	Analog Green
12	N/C	C3	Analog Blue
13	N/C	C4	Analog Horizontal Sync
14	+5V Power	C5	Analog Ground (analog R, G, B return)
15	Ground (return for +5V, HSync, and VSync)		

Connecting a PS/2 Keyboard and Mouse

Your DA-683 embedded computer comes with a PS/2 mini-DIN connector to connect to a PS/2 keyboard and PS/2 mouse by using a Y-type cable. This 6-pin mini-DIN connector has the pin assignments shown below.

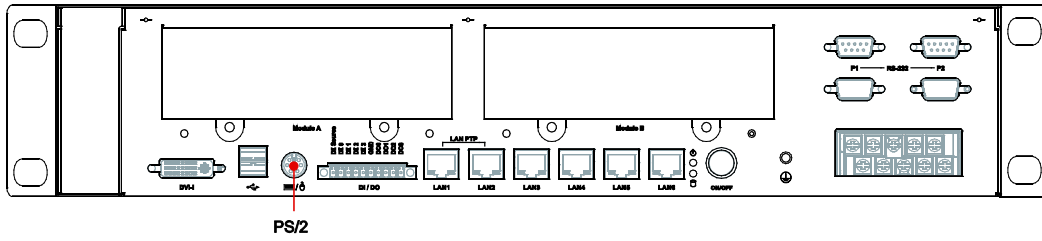

	Pin No.	Signal Definition
	1	PS/2 Keyboard Data
	2	PS/2 Mouse Data
	3	GND
	4	VCC
	5	PS/2 Keyboard Clock
	6	PS/2 Mouse Clock

Use the Y-type cable to convert the mini-DIN connector into two 6-pin mini-DIN connectors to connect both a PS/2 keyboard and PS/2 mouse at the same time. (The Y-type cable is not included in the accessory package. It should be purchased separately. You may also use the USB ports to connect your USB-based keyboard and mouse.)



ATTENTION

Please note that without the Y-type cable, the PS/2 connector on the DA-683 can only work with a PS/2 keyboard. A PS/2 mouse will not function when directly connected to the PS/2 connector on the DA-683 embedded computer.

Connecting USB Devices

The DA-683 embedded computer has four USB 2.0 ports: two are on the front panel, and two are on the rear panel. All of the ports are UHCI, Rev 2.0 compliant and support Plug & Play and hot swapping. These ports can be used to connect USB devices, such as a keyboard, mouse, USB flash disk, and USB CD-ROM. In addition, both USB ports support system boot up, which can be activated by modifying the BIOS settings. The chapter "BIOS Setup" describes the configuration process in detail.

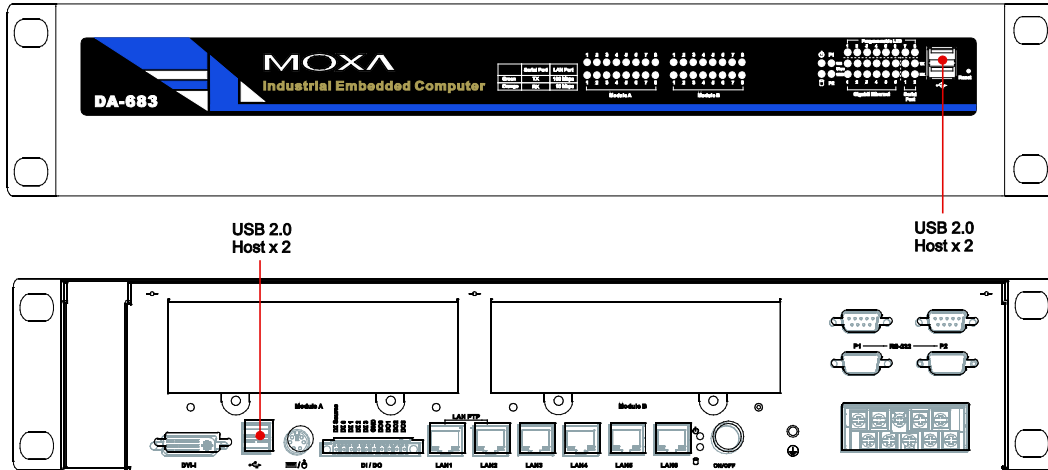

LAN Ports

The DA-683 has 6 10/100/1000 Mbps LAN ports. When the cable is properly connected, the LEDs on the RJ45 connectors will glow to indicate a proper connection.

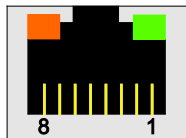
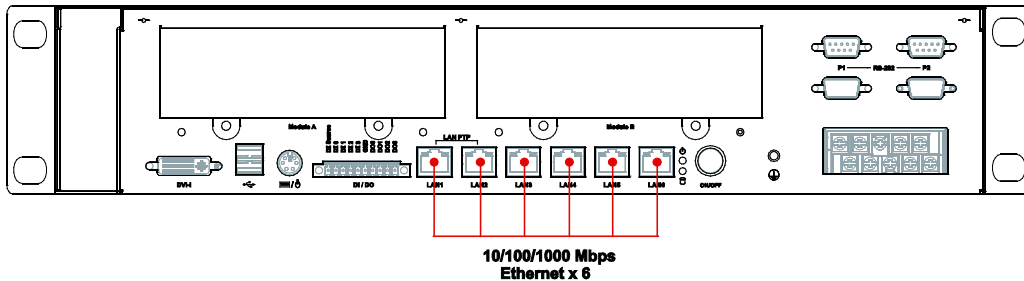

Pin No.	Gigabit Ethernet Signal
1	TRD (0)+
2	TRD (0)-
3	TRD (1)+
4	TRD (2)+
5	TRD (2)-
6	TRD (1)-
7	TRD (3)+
8	TRD (3)-

LED	Color	Description
Ethernet Port 1000 Mbps	Green	1000 Mbps of Ethernet Port is active
	Off	No activity
Ethernet Port 100 Mbps	Yellow	100 Mbps of Ethernet Port is active
	Off	10 Mbps or no activity

The default IP addresses and netmasks of the Gigabit LAN ports are as follows:

	Default IP Address	Netmask
LAN 1	192.168.3.127	255.255.255.0
LAN 2	192.168.4.127	255.255.255.0
LAN 3	192.168.5.127	255.255.255.0
LAN 4	192.168.6.127	255.255.255.0
LAN 5	192.168.7.127	255.255.255.0
LAN 6	192.168.8.127	255.255.255.0

NOTE Please note that the XPE models use DHCP.

Connecting Digital Input/Output Channels

The DA-683 computer comes with 4 digital input channels and 4 digital output channels located on the rear panel. These DI/DO channels can be connected with the terminal block. See the following figures for the locations of the DI/DO channels and the wiring methods.

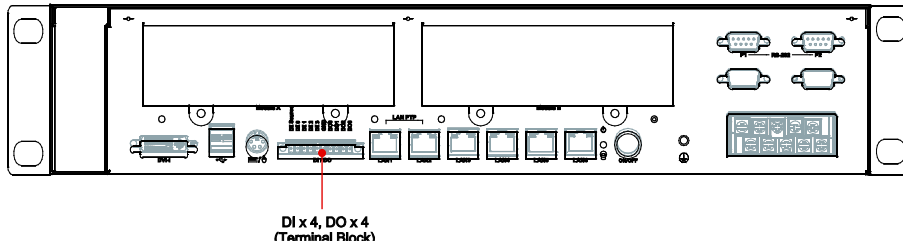

Digital Input Dry Contact Wiring

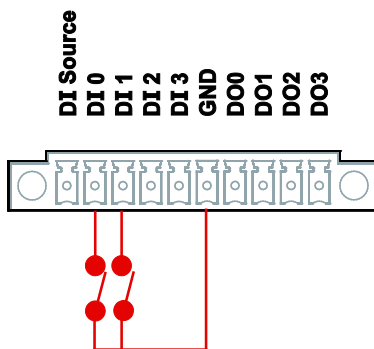

Digital Input Wet Contact Wiring

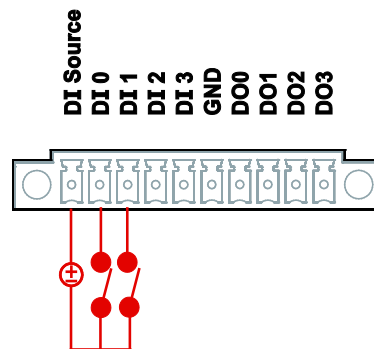

Digital Output Wiring

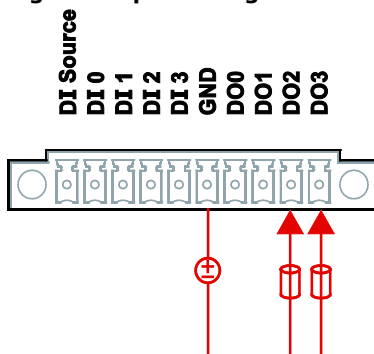

Upgrading the Memory Module

The DA-683 embedded computer supports one 200-pin DDR2 667 SODIMM module of up to 2 GB. One DDR2 SDRAM memory module is pre-installed. To upgrade the DDR2 SDRAM memory module, follow these instructions:

1. Disconnect the DA-683 from the power source.
2. The DA-683's memory module is located inside the DA-683. Use a screwdriver to remove the screws on the top cover of the DA-683.

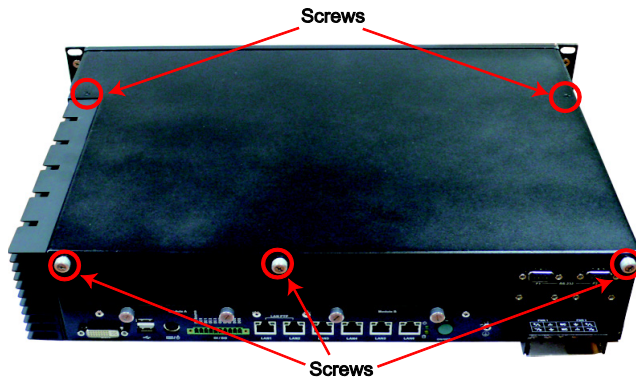

3. After removing the cover, you will see the DDR2 SDRAM module.

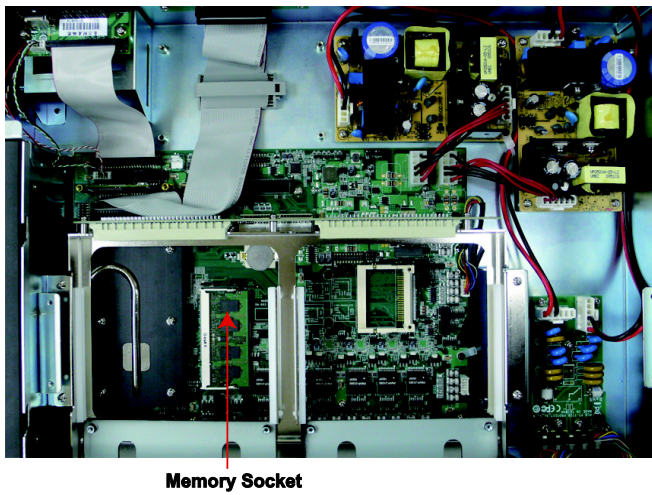

4. To upgrade the memory, you need to remove the original memory by pushing two clutches at both sides of the module.

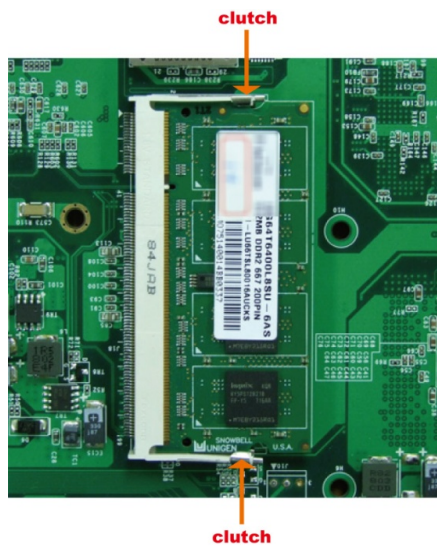

5. Gently insert the new memory into the module. Make sure the direction is correct.

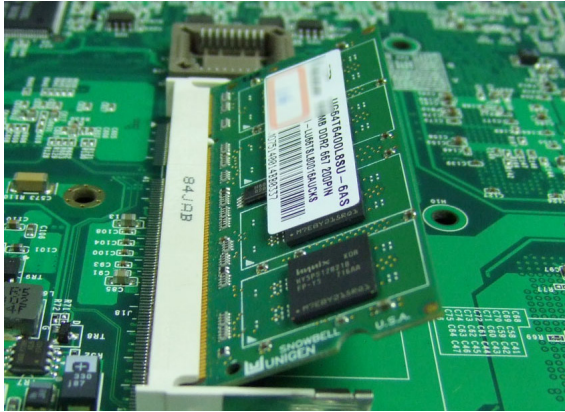

6. Push the memory all the way down to complete installation.

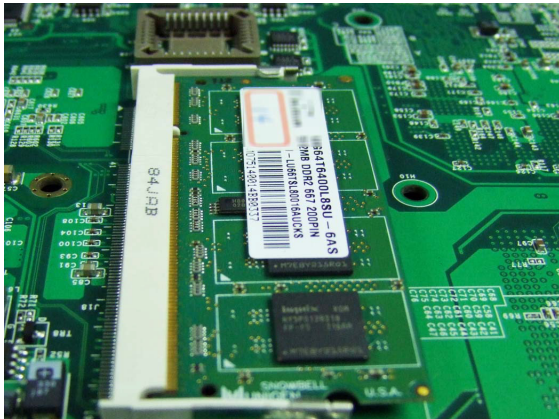

Installing a CompactFlash Card

The DA-683 embedded computer comes with a CompactFlash socket. To insert a CompactFlash card, follow these instructions.

1. Disconnect the DA-683 from its power source.
2. The DA-683's CompactFlash socket is located inside the DA-683. Use a screwdriver to remove all the screws on the top cover of the DA-683.

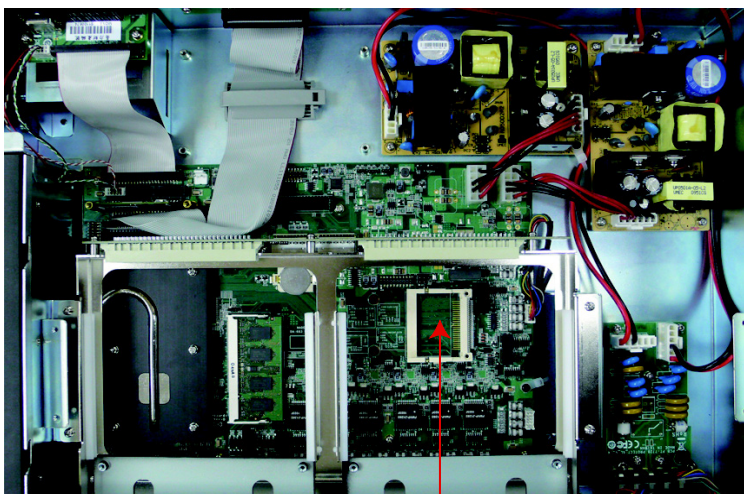

**CompactFlash Card
Socket**

3. Insert the CompactFlash card into the socket. Push downwards to make sure that the card is firmly inserted.



ATTENTION

Make sure you insert the card in the right direction. The card cannot be inserted if you insert the card in the wrong direction.



ATTENTION

The DA-683 embedded computer does not support the CompactFlash hot swap and PnP (Plug and Play) functions. It is necessary to remove power source first before inserting or removing the CompactFlash card.

Installing a SATA Hard Disk

The DA-683 embedded computer has one or two SATA connectors for SATA hard disks. To install a 2.5-inch SATA hard disk, follow these instructions.

4. Disconnect the DA-683 from its power source.
5. Open the top cover of the DA-683. Refer to the following figure for the specific location for hard disk installation..

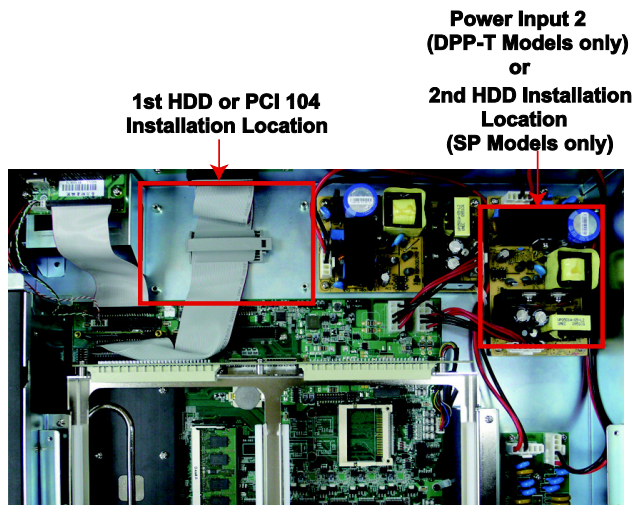

Please note that for SP models, the DA-683 allows users to install two hard disk drives inside the computer. Users can install the hard disks at the first and second hard disk bays. For DPP-T models, users can only install one hard disk at the first bay, as the second installation bay has been occupied by the second power input.

6. User two screws per side to attach the hard disk in the bracket. If you need to install the second hard disk, simply attach it on the upper tier of the bracket.

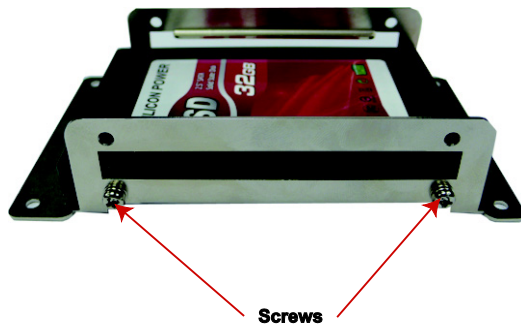

7. Connect the power cable and the SATA cable to the hard disk.



8. You need to unscrew the cable cover on the hard disk installation bay. Open the cover and then remove the screws on the cover.



9. Place the hard disk bracket on the computer; fasten the bracket with four screws on the corners.



- Connect the power cable and SATA cable to the connectors on the computer.

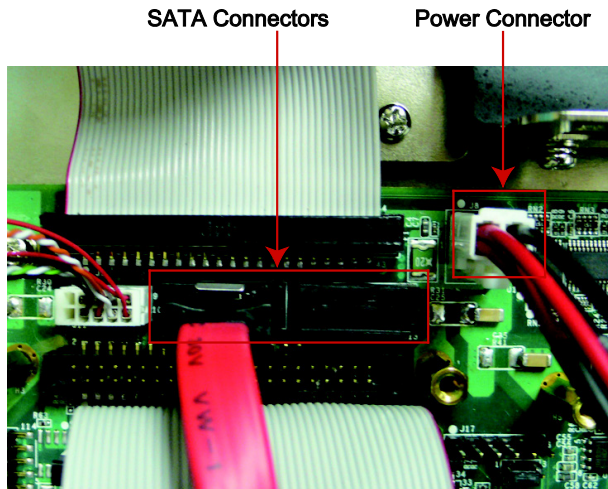

ATTENTION

The SATA hard disk cable and SATA power cable are not included in the basic shipment of the DA-683 embedded computer. You need to buy the FK-76127-01 Hard Disk Installation Package for connecting the SATA hard disk cable and SATA power cable.

Installing a PCI 104 Board

The DA-683 computer comes with one PCI 104 connector that allows users to install a PCI 104-based device. However, this connection is located at the first hard drive installation bay. If you would like to use the PCI 104 connector, we suggest you install the hard disk at the second hard ydisk installation bau.

Follow these steps to install the PCI 104 board.

- Fasten the four screws on the PCI 104 board bracket.

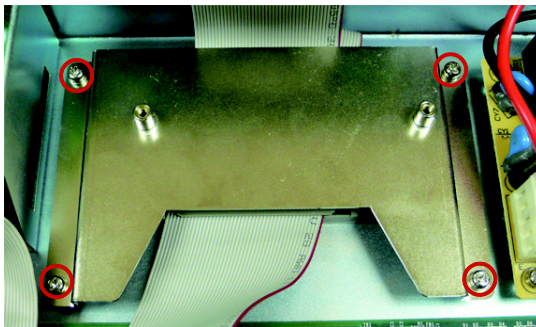

- Connect the PCI 140 board to the connector on the computer. The connector is just located below the bracket. When finished, fasten the two screws on the upper part of the PCI 104 board.

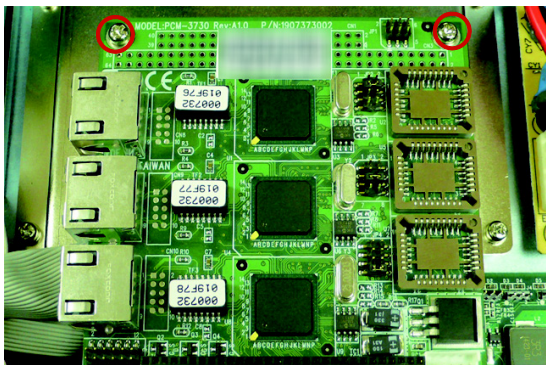

Upgrading a DOM

The DA-683 comes with a IDE-based DOM in which the operating system has been installed. To upgrade this DOM, follow these step.

1. Disconnect the DA-683 from its power source.
2. Open the top cover of the DA-683. Refer to the following figure for the specific location for the DOM installation.

DOM Location

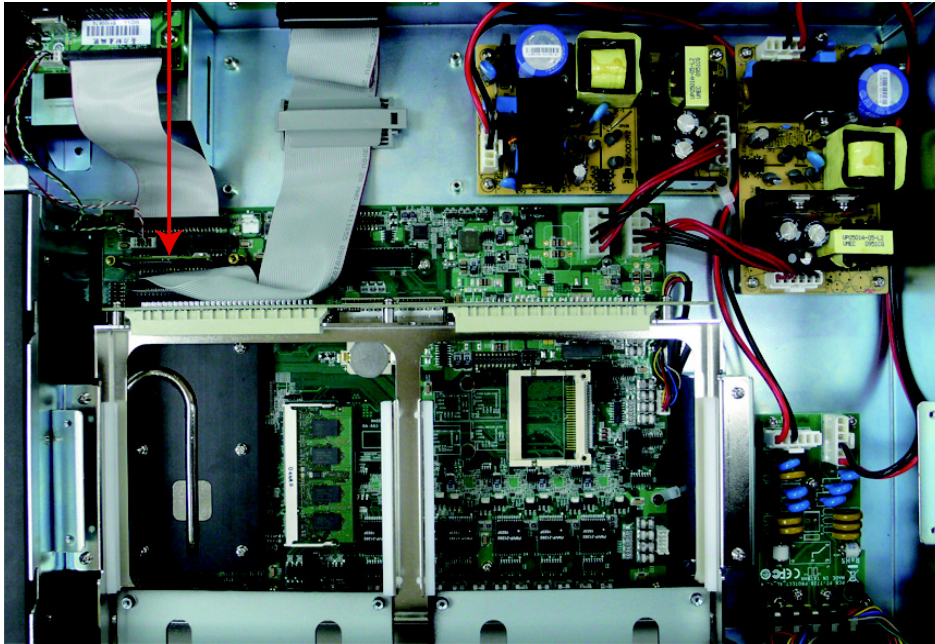

3. Remove and pull up the DOM carefully.
4. Insert the new DOM and push downwards to finish.

DOM

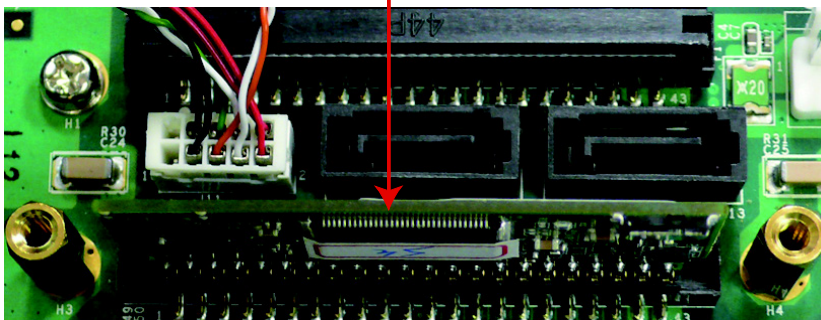

Inserting and Removing Expansion Modules

The DA-683 embedded computer has two expansion slots for inserting expansion modules. Expansion modules can be installed in either on Slot A or Slot B. To insert or remove expansion modules, follow these instructions.

1. Disconnect the DA-683 from the power source.

2. Unscrew expansion module A or module B on the rear panel.

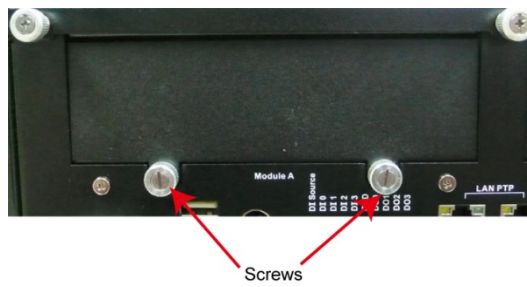

3. Carefully insert or remove the expansion module by pushing or pulling on the two screws at the same time. By pushing or pulling on the two screws evenly, you can ensure that the board is inserted or removed without being damaged.

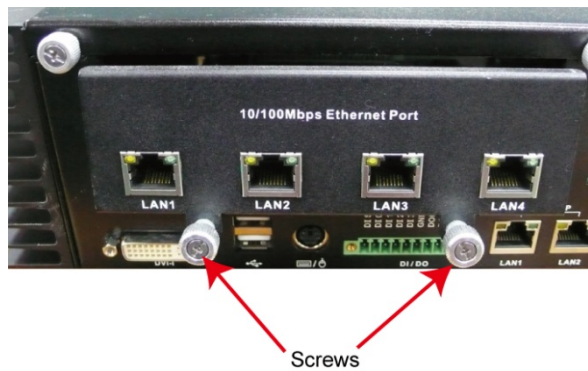

This chapter describes the BIOS settings of the DA-683 Computer. The BIOS is a set of input/output control routines for peripherals. The BIOS is used to initialize basic peripherals and helps boot the operating system before the operating system is loaded. The BIOS setup allows the user to modify the system configurations of these basic input/output peripherals. All of the configurations will be stored in the NVRAM (Flash part), which retains the system information after system reboots or the power is removed.

The following topics are covered in this chapter:

- ❑ **Entering the BIOS Setup Utility**
- ❑ **Main Information**
- ❑ **Modifying the BIOS Main Settings**
 - Advanced Settings
 - Security Settings
 - Power Settings
 - Boot Settings
 - Exit Settings
- ❑ **Upgrading the BIOS**

Entering the BIOS Setup Utility

To enter the BIOS setup utility, press the "F2" key while the system is booting up. The main BIOS Setup screen will appear.

A basic description of each function key is listed at the bottom of the screen. Refer to these descriptions to learn how to scroll about the screen, how to select by pressing "Enter," and how to use the other hot keys listed below.

F1: General Help

F5/F6: Change Values

F9: Setup Defaults

F10: Save and Exit

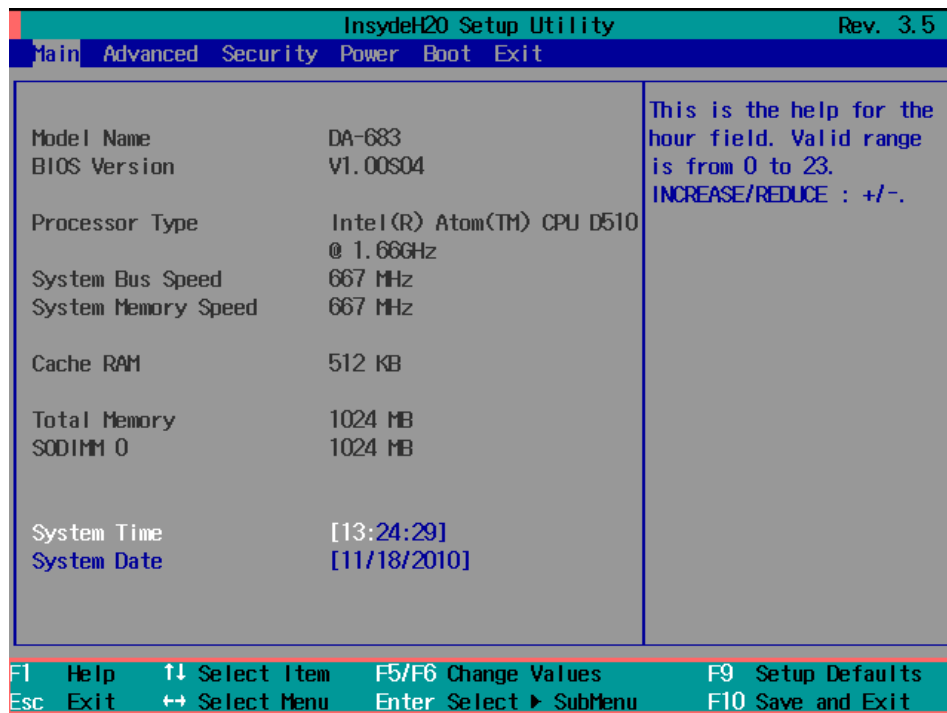

Main Information

The main page indicates the system information, such as model name, BIOS version, and CPU type. User may view the basic system hardware information in the page.

Modifying the BIOS Main Settings

Advanced Settings

The "Advanced Features" screen will appear when choosing the "Advanced" item from the main menu.

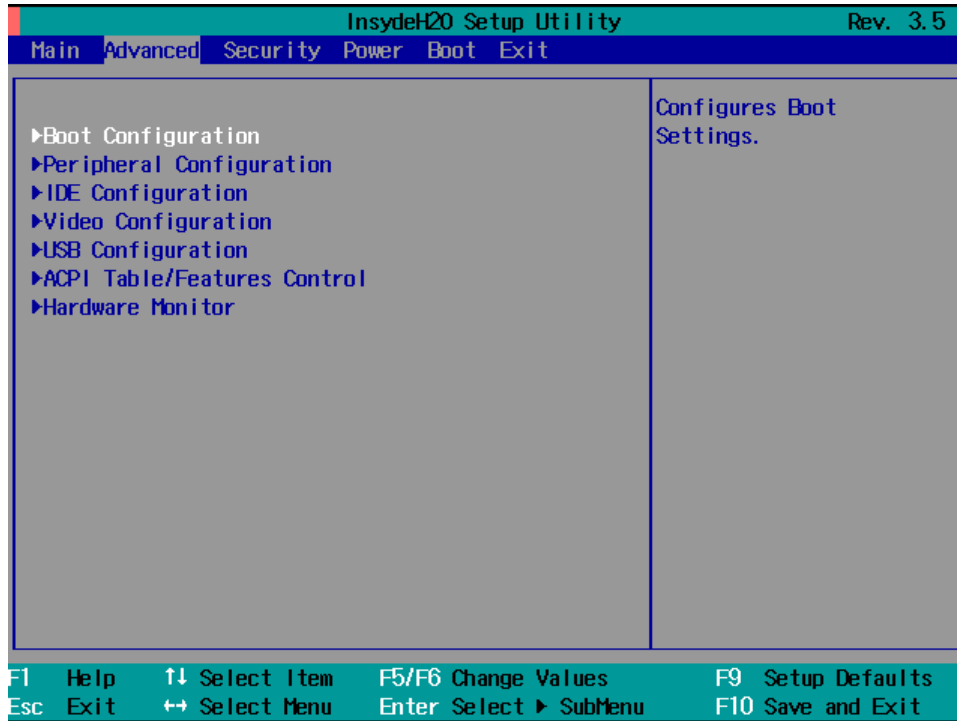

Boot Configuration

This item allows users to configure the default value of Numlock.

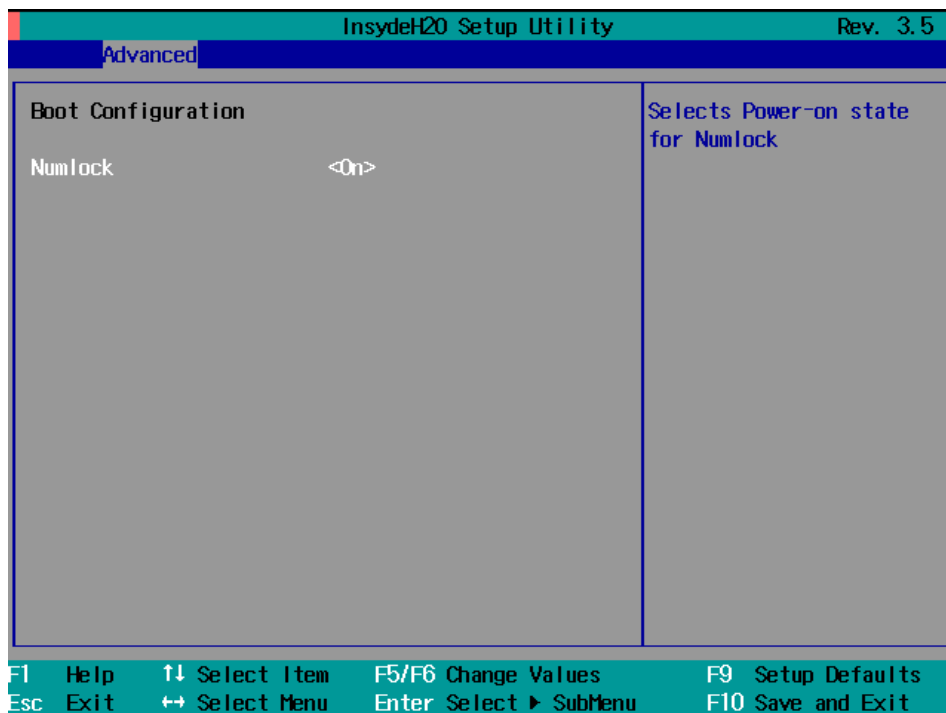

Option: On (default), Off.

Peripheral Configuration

This item allows you to configure the parallel port and audio device.

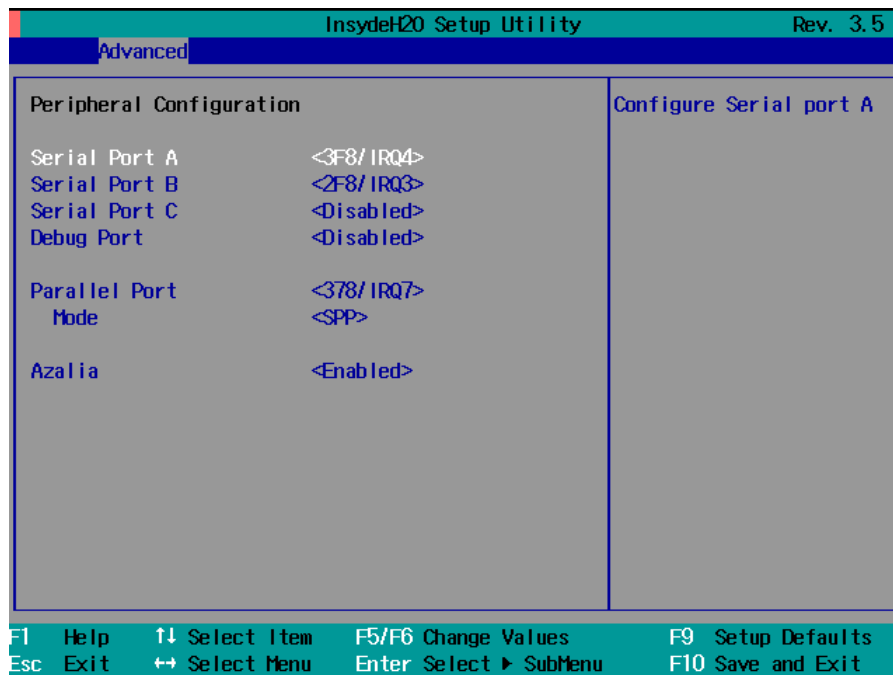

Serial Port A

This item allows you to configure the parallel port.

Options: 378/IRQ7 (default), Disabled

Serial Port B

This item allows you to configure the parallel port.

Options: 2F8/IRQ3 (default), Disabled

Serial Port C

This item allows you to configure the parallel port.

Options: 3E8/IRQ5, Disabled (default)

Debug Port

This item allows you to configure the debug port. Please note that this port should be used only by programmers who are familiar with debugging.

Options: 2E8/IRQ6, Disabled (default)

Parallel Port

This item allows you to configure the parallel port.

Options: 378/IRQ7 (default), Disabled

Mode

This setting allows you to configure the mode for the parallel port.

Options: SPP (default), EPP, ECP, EPP+ECP

Azalia

The item allows you to configure if the system will automatically detect the Azalia codec..

Options: Enabled (default), Disable.

IDE Configuration

This item allows you to configure the hard disk controllers.

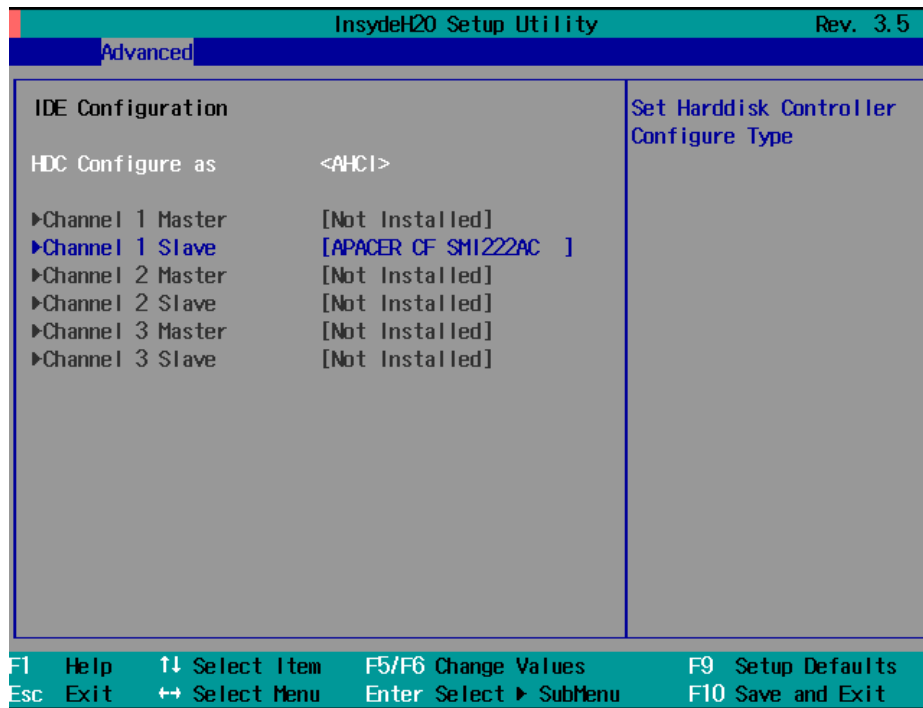

HDC Configure As

This item allows you to configure the hard disk type.

Options: AHCI (default), PATA Only, SATA Only, IDE Non-Combined

Channel Master 1 to 3

This setting displays the storage devices installed on the Master mode in the computer. These storage devices could be DOM, hard disk drives or a CF card.

Channel Slave 1 to 3

This setting displays the storage devices installed on the Slave mode in the computer. These storage devices could be a DOM, hard disk drives, or a CF card.

Video Configuration

This item allows you to configure the video settings.

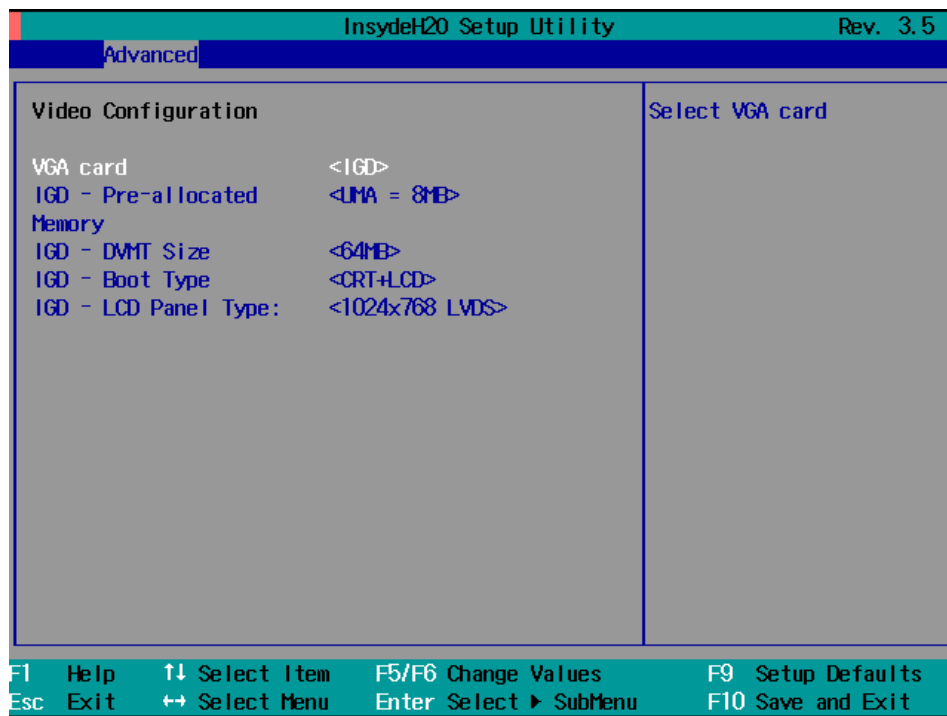

VGA card

This item allows you to select the onboard VGA chipset or the external VGA card installed in the PCI slot..

Options: IGD (default), PCI

IGD – Pre-Allocated

This item allows you to configure the pre-allocated capacity for the graphic memory capacity.

Options: 8 MB (default), 1 MB

IGD – DVMT Size

This item allows you to configure the capacity of the DVMT 5.0 used by the internal graphics device.

Options: 64 MB (default) , 128 MB, 224 MB

IGD – Boot Type

This item allows you to select the video device which will be activated during POST.

Options: CRT+LCD (default), CRT, LCD

IGD – LCD Panel Type

This item allows you to select the LCD panel type and the resolution.

Options: 1024x768 LVDS (default), 800x600 LVDS

USB Configuration

This item allows you to configure the USB settings.

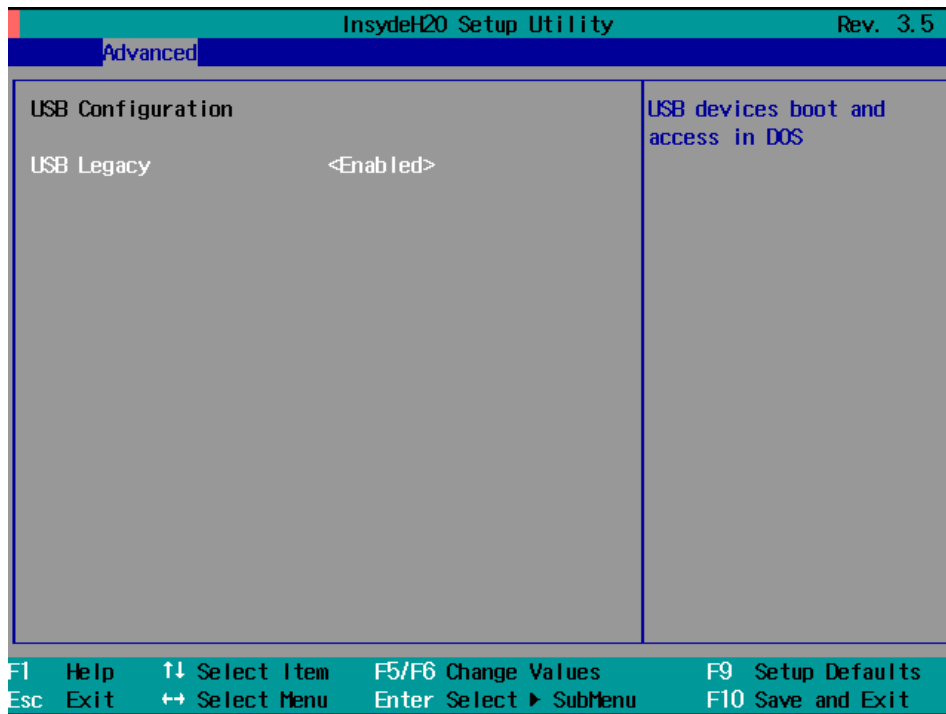

USB Legacy

This item allows you to configure the USB devices that can be accessed during boot-up and in DOS.

Options: Enabled (default), Disabled

ACPI Table/Features Control

This item allows you to configure FACP and HPET functions.

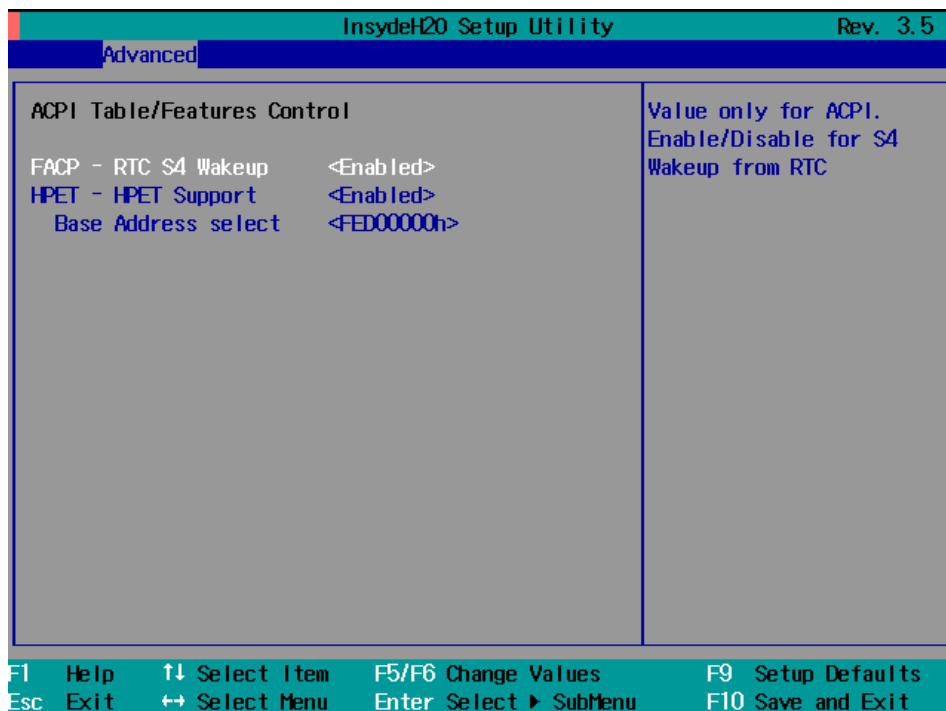

FACP – RTC S4 Wakeup

This item allows you to enable the operating system through RTC when in sleep mode..

Options: Enabled (default), Disabled

HPET – HPET Support

This item allows you to enable/disable the HPET (High Precision Event Timer) function.

Option: Enabled (default), Disabled

Base Address Select

This item allows you to select the memory address range for the HPET.

Options: FED00000h (default), FED01000h, FED02000h, FED03000h

Hardware Monitor

This item allows you to view the status of the hardware utility. You may check various parameters for the hardware status, such as CPU temperature, system temperature, and CPU voltage.

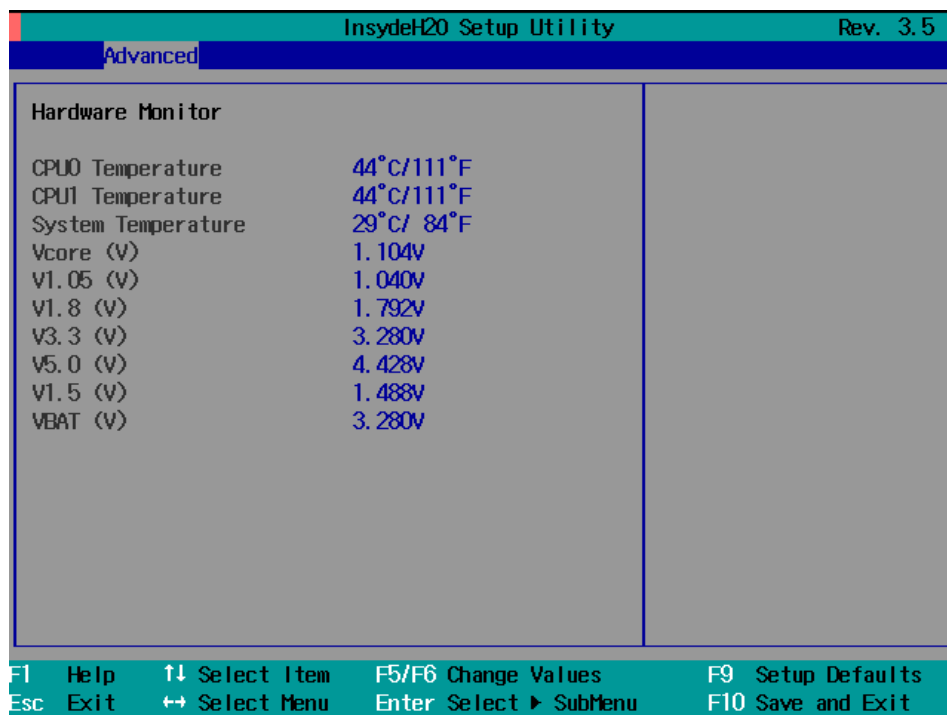

Security Settings

The section allows users to configure security settings with supervisor password and user password.

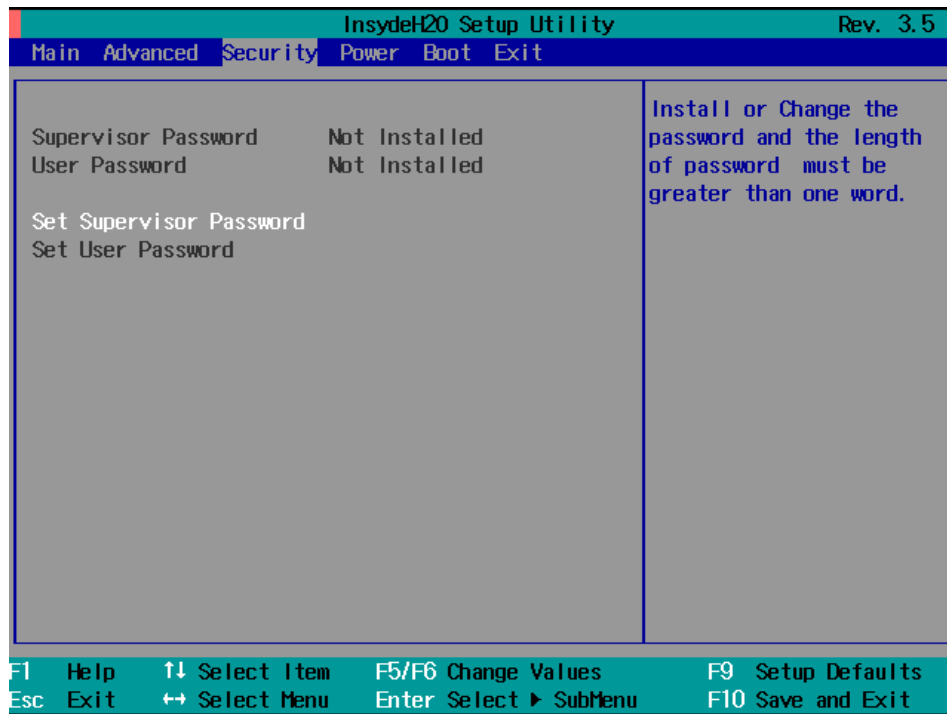

Set Supervisor Password

This item allows you set the supervisor password. Select and then enter the password, and then confirm the password again.

Set User Password

This item allows you set the supervisor password. Select and then enter the password, and then confirm the password again.

Power Settings

The section allows users to configure power settings.

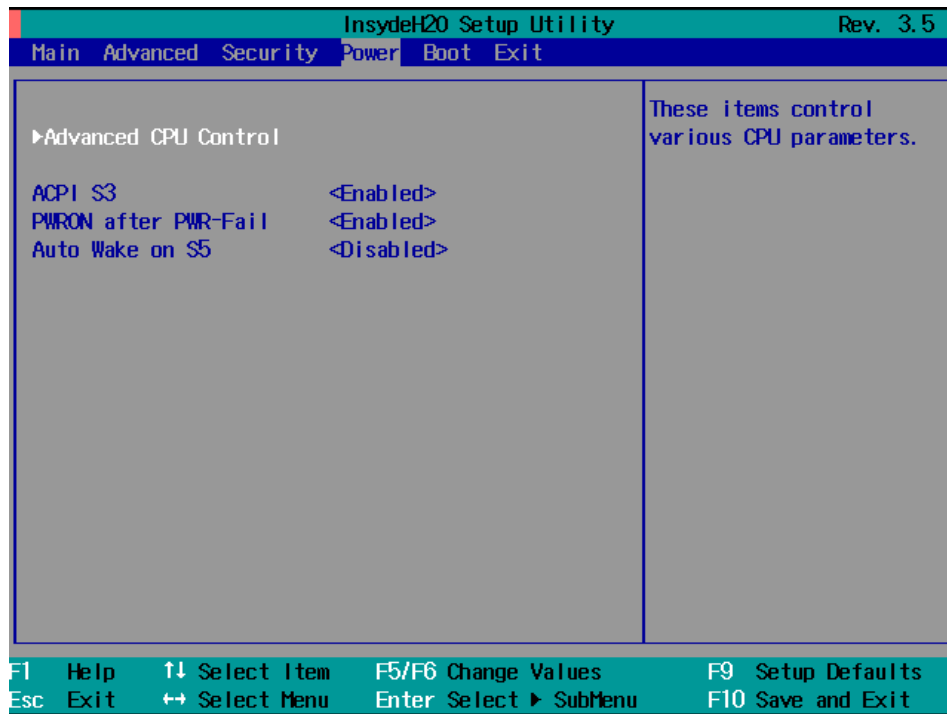

Advanced CPU Control

ACPI S3

This item allows you to enable/disable Processor Performance States (P-States) function.

Options: Disabled (default), Enabled

PWRON after PWR-Fail (Power on after Power Fail)

This item allows you to configure the power on after power fail function.

Options: Off, On (default), Former-Sts

Auto Wake on S5

This item allows you to configure the wake up function on S5 status.

Options: Disabled (default)

By Every Day: You may specify the time to wake up every day.

By Day of Month: You may specify the date each month to wake up the system.

Thermal Mode

This item allows you to configure the thermal control circuit portion of the thermal monitor..

Options: TM1 (default), Disabled

HT Support

This item allows you to configure the Hyper-Threading (HT) function.

Options: Auto (default), Disabled

Use XD Capability

This item allows you to enable/disable the Intel XD function..

Options: Enable (default), Disabled

Boot Settings

The section allows users to configure boot settings.

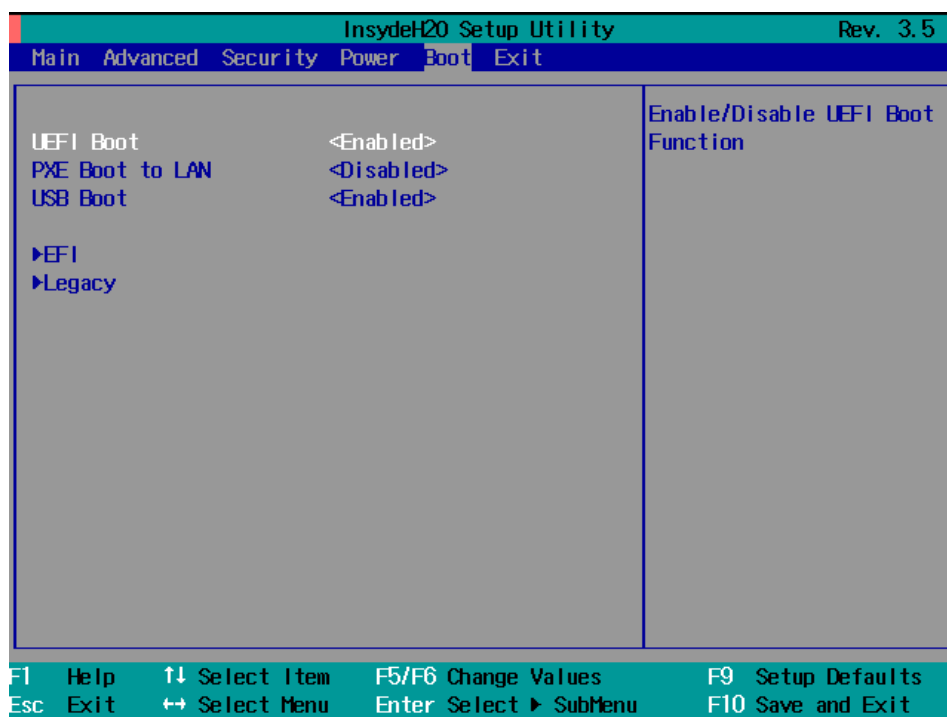

UEFI Boot

This item allows you to enable/disable the UEFI boot function.

Options: Enabled (default), Disabled

PXE Boot to LAN

This item allows you to configure the PXE boot to LAN function.

Options: Disabled (function), enabled

USB Boot

This item allows you to enable/disable the USB boot function..

Options: Enabled (default), Disabled

EFI

This item displays the boot selection for the UEFI boot function.

Legacy

Normal Boot Menu

This item allows you to configure the boot menu.

Options: Normal (default), Advance

Boot Type Order

This item allows you to select the boot order. Use F5/F6 to change values.

Options: Hard Disk Drive (default), CD/DVD-ROM Drive, USB, Others.

USB

This item allows you to view the USB device installed in the computer.

Exit Settings

The section allows users to configure exit settings.

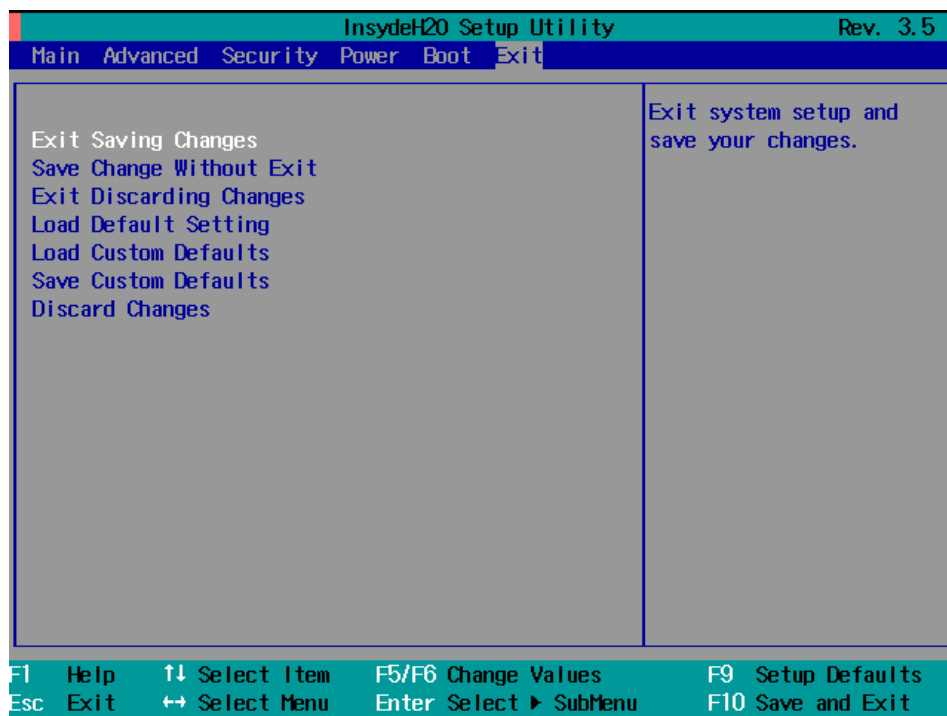

Exit Saving Changes

This item allows you to exit and save the values you have just configured.

Options: Yes (default), No

Save Change Without Exit

This item allows you to save changes but not to exit the BIOS settings.

Options: Yes (default), No

Exit Discarding Changes

This item allows you to exit and without saving any values you have just changed.

Options: Yes (default), No

Load Defaults Setting

This item allows you to load default values for the BIOS settings

Options: Yes (default), No

Load Custom Defaults

This item allows you to load custom default values for the BIOS settings

Options: Yes (default), No

Save Custom Defaults

This item allows you to save custom default values for the BIOS settings

Options: Yes (default), No

Discard Changes

This item allows you to discard all settings you have just configured.

Options: Yes (default), No

Upgrading the BIOS

This section describes how to upgrade the BIOS. However, please note that upgrading the BIOS involves high risk of damage to your computer. We strongly recommend that you contact Moxa's TS staff for assistance and obtain all necessary tools and files before attempting to upgrade.

Step 1: Create a Bootable USB Disk.

We suggest you use the HP USB Disk Format Tool to create a bootable USB disk. You may download this tool from the Internet. Search the Internet using the phrase "HP USB Disk Storage Format Tool", and then download the tool from one of the listed websites.

You will also need to download the FreeDos system files **kernel.sys** and **command.com** from <http://www.freedos.org/kernel/>.

Copy DOS system files **kernel.sys** and **command.com** to a specified directory (**C:\FreeDOS** in this example).

Start the HP USB Disk Storage Format Tool and select the USB device that you want to use as a bootable disk in the **Device** drop down box.

Select **FAT** in the **File system** drop down box.

Type the disk name in the **Volume label field**.

Check the option **Create a DOS startup disk** under format options.

Specify the directory of the system files (for example, **C:\FreeDOS**).

Click **Start** to format and create the USB disk.

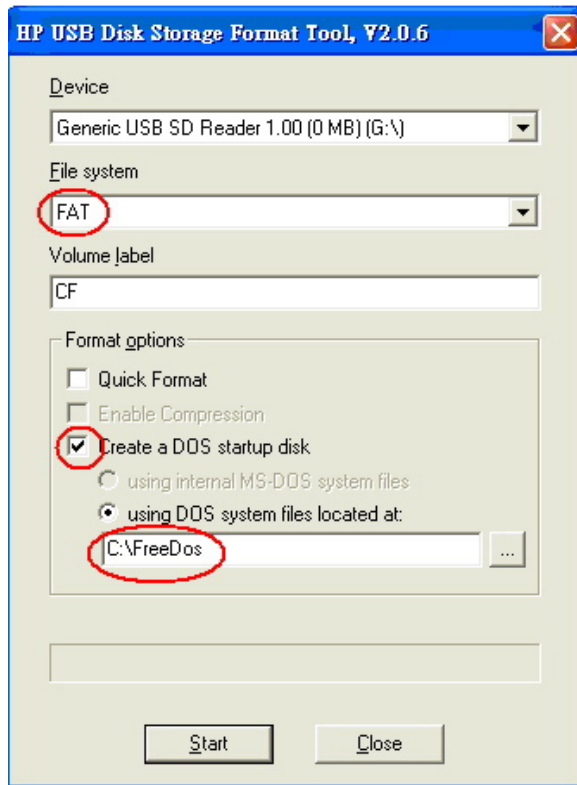

ATTENTION

We suggest you use a USB drive with under 2 GB in disk space, as larger USB drives may not support the FAT file format and consequently fail to boot.

Step 2: Prepare the Upgrade File.

You must use the BIOS upgrade installation file to upgrade the BIOS. You can send your request to Moxa's technical support team at support@moxa.com to get an updated version of the BIOS.

1. Get the BIOS upgrade installation file. The file name should have following format: **683xxSxx.exe (xx refers to version numbers)**
2. Copy the file to the Bootable USB Disk.

Step 3: Run the upgrade program on the DA-683 computer

1. Reboot the computer, press F12 while booting up to go to the Boot Manager
2. Select USB Disk as the first boot source. Press Enter to continue.

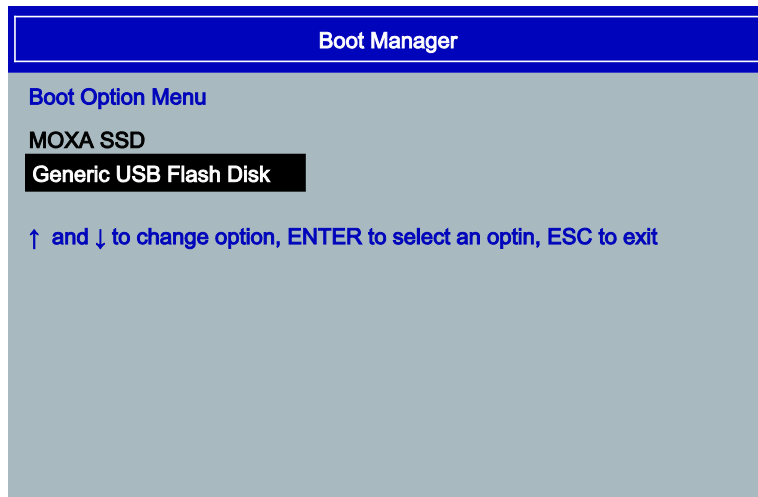

3. Once the computer boots, a DOS screen will appear. Go to the directory where the upgrade file is located. For example, if the upgrade file is stored in the DA683 folder, type **cd DA683**

```
C:\ cd DA683
```

4. Run the upgrade program by typing **68310S05.exe**. Please note that the upgrade filename may vary depending on the firmware version.

```
C:\ DA683>68310S05.exe
```

5. The upgrade program will run. Please wait until the procedure to be finished.

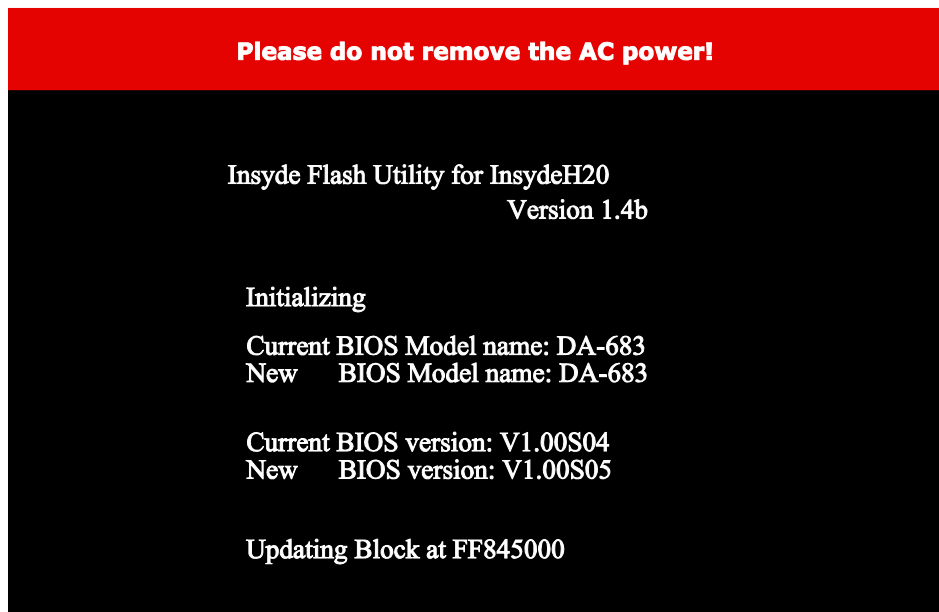

6. Once the upgrade is finished, the computer will automatically reboot. You may check the BIOS version in Main page of the BIOS Setup

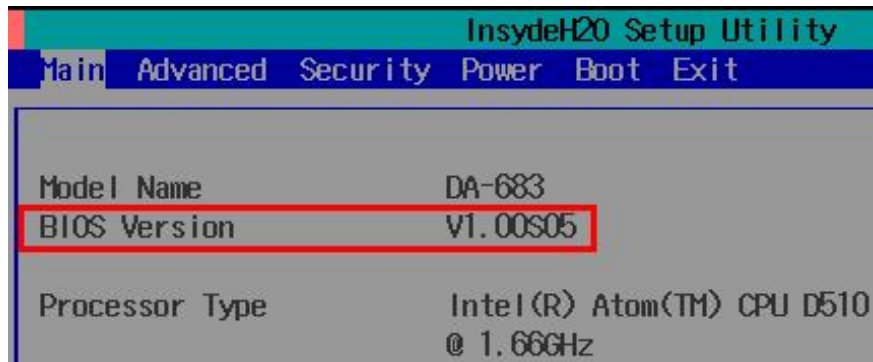
**ATTENTION**

Do NOT switch off the power supply during the BIOS upgrade, since doing so may cause the system to crash.

Safety Installation Instructions

A. RTC Battery Warning

CAUTION: There is a risk of explosion if battery is replaced by an incorrect type. Dispose of used batteries according to the instructions.

B. Fuse Warning

CAUTION: For continued protection against fire, replace only with same type and rating of fuse.

C. Rackmount Warning

The following or similar rackmount instructions are included with the installation instructions:

(1) Elevated Operating Ambient: If installed in a closed or multi-unit rack assembly, the operating ambient temperature of the rack environment may be greater than the room ambient temperature. Therefore, consideration should be given to installing the equipment in an environment compatible with the maximum ambient temperature (T_{ma}) specified by the manufacturer.

(2) Reduced Air Flow: Installation of the equipment in a rack should be such that the amount of air flow required for safe operation of the equipment is not compromised.

(3) Mechanical Loading: Mounting of the equipment in the rack should be such that a hazardous condition is not achieved due to uneven mechanical loading.

(4) Circuit Overloading: Consideration should be given to the connection of the equipment to the supply circuit and the effect that overloading of the circuits might have on overcurrent protection and supply wiring. Appropriate consideration of equipment nameplate ratings should be used when addressing this concern.

(5) Reliable Grounding: Reliable grounding of rack-mounted equipment should be maintained. Particular attention should be given to supply connections other than direct connections to the branch circuit (e.g., by using power strips).

D. High Temperature Warning

(1) This equipment is intended to be used in Restrict Access Location, like computer room. The access can only be gained by SERVICE PERSONS or by USERS who have been instructed about the metal chassis of the equipment is so hot that service persons have to pay special attention or take special protection before touching it. Further, the access is through the use of key or security identity system. Only authorized by well trained professional person can access the restrict access location.

(2) External metal parts are hot!! Before touching it, special attention or protection is necessary.



Regulatory Statement Approval



This device complies with part 15 of the FCC Rules. Operation is subject to the following two conditions: (1) This device may not cause harmful interference, and (2) this device must accept any interference received, including interference that may cause undesired operation.

Class A: FCC Warning! This equipment has been tested and found to comply with the limits for a Class A digital device, pursuant to part 15 of the FCC Rules. These limits are designed to provide reasonable protection against harmful interference when the equipment is operated in a commercial environment. This equipment generates, uses, and can radiate radio frequency energy and, if not installed and used in accordance with the instruction manual, may cause harmful interference to radio communications. Operation of this equipment in a residential area is likely to cause harmful interference in which case the user will be required to correct the interference at his own expense.



European Community

Warning:

This is a Class A product. In a domestic environment this product may cause radio interference in which case the user may be required to take adequate measures.